

Russian Regulators: Part II
PP-302 / -302A
for the
65-Watt Г-414 Generator



Ernie Franke
eafranke@tampabay.rr.com

6-Volt Electro-Magnetic (Relay-Type) Regulator (PP-302/-302A) for the Г-414 10-Amp Generator

• Background

- Voltage Regulators Paired with Specific Generators/Alternators**
- Time-Line for Generators/Alternators/Regulators**
- Specs for 6-Volt Г-414 Compatible Generator**
- Generator Application in Ural (M-62,-63,-66)/ Dnepr (K-650,-750, -750M, MW-750, -750M, MT-9,-12) Wiring**

• What Is the PP-302?

- External Voltage Regulator for Г-414 (10-Amp/65-Watt) Generator**
- Electro-Magnetic (Relay-Type) Design**
- Years of Application: 1963 -to- 1974**
- Upgraded from PP-31/31A (6-Volt Regulator)**
- Later Superseded by PP-330 Regulator in 1974**

• How Does It Work?

- Regulates Alternator Output Voltage to 6-Volts**
- Supplies Exciter Current to Vary Stator Magnetic Field**
- Provides Constant Voltage Regardless of Rotor Speed and Load**

• Circuit Description and Operation

• Replacement

- Replacement Purchased On-Line over Internet**

The Relay-Regulator (PP-302, a.k.a RR-302) was the final 6-Volt and the first 12-Volt regulator used on Ural and Dnepr motorcycles.

Types of Generators/Alternators for Ural (Урал) and Dnepr (Днепр) (01/10)

eafranke@tampabay.rr.com

Generator/ Alternator	Type	Vintage	Nominal Voltage	Current	Nominal Power	Regulator	Motorcycles	
							Ural(IMZ)	Dnepr (KMZ)
Г-11 (G-11) (P/N: 72181)	DC Generator	1941- 1951	6-Volt (7-Volt)	7-Amp	45-Watts	PP-1 PP-31 (1950)	M-72	Not Used
Г-11А (G-11А) (P/N: 72181-А)	DC Generator	1952- 1957	6-Volt (7-Volt)	7-Amp	45-Watts	PP-31 (1950) PP-31А (1956)	M-72, M-72M, M-61	M-72, M-72N, early K-750
Г-414 (G-414) (P/N: 750181)	DC Generator	1957- 1974	6-Volt (7-Volt)	10-Amp	65-Watts	PP-31А (1956) PP-302 (1963) PP-302А	M-62, M-63, M-66	K-650, later K-750, K-750M, MW-750, MW-750M, MT-8, MT-9, MT-12
Г-424 (G-424) (P/N: 3701000)	Alternator (Built-in Rectifier)	1974- 1998	12-Volt (14-Volt)	11-Amp (aka 14-A)	150-Watts	PP-302А PP-330 33.3702 (1992)	M-67, M67.36, IMZ 8.103 Series	MW-650, MW-650M, MT-10, MT-10.36, MT-11, MT-14, MT-16
Hitachi (Limited Appearance)	Alternator/ Starter	1998- 1998.5	12-Volt (14-Volt)	18-Amp	300-Watts	Internal to Alternator??	IMZ 8.103 and 8.107 "650" Series	Not Used
14.3771 (P/N: 14.3771- 010)	Alternator (Built-in Rectifier & Regulator)	1998.5 -2004	12-Volt (14-Volt)	35-Amp	500-Watts (aka 350-W)	Internal to Alternator (YA212A11E)	IMZ 8.103, 8.103X, 8.123, 8.123X "650 & 750" Series	Not Used
Nippon Denso (P/N: IMZ-8.1037- 18092)	Alternator (Built-in Rectifier & Regulator)	2004- present	12-Volt (14-Volt)	55-Amp	770-Watts	Internal to Alternator (126000-0600)	IMZ 8.103, 8.103X, 8.123, 8.123X "750" Series	Not Used

Notes:

- Nomenclature: The Cyrillic letter "Г" transliterates (Russian-to-Latin) to "G" or "L" or "T." Thus we see Г-414 or G-414 or L-414 or T-414, all for the same part.**
- Cannot use Alternator with discharged battery or without battery.**

Ural (Урал) - Днепр (Днепр) Generator/Alternator Time-Line (12/09)

eafranke@tampabay.rr.com

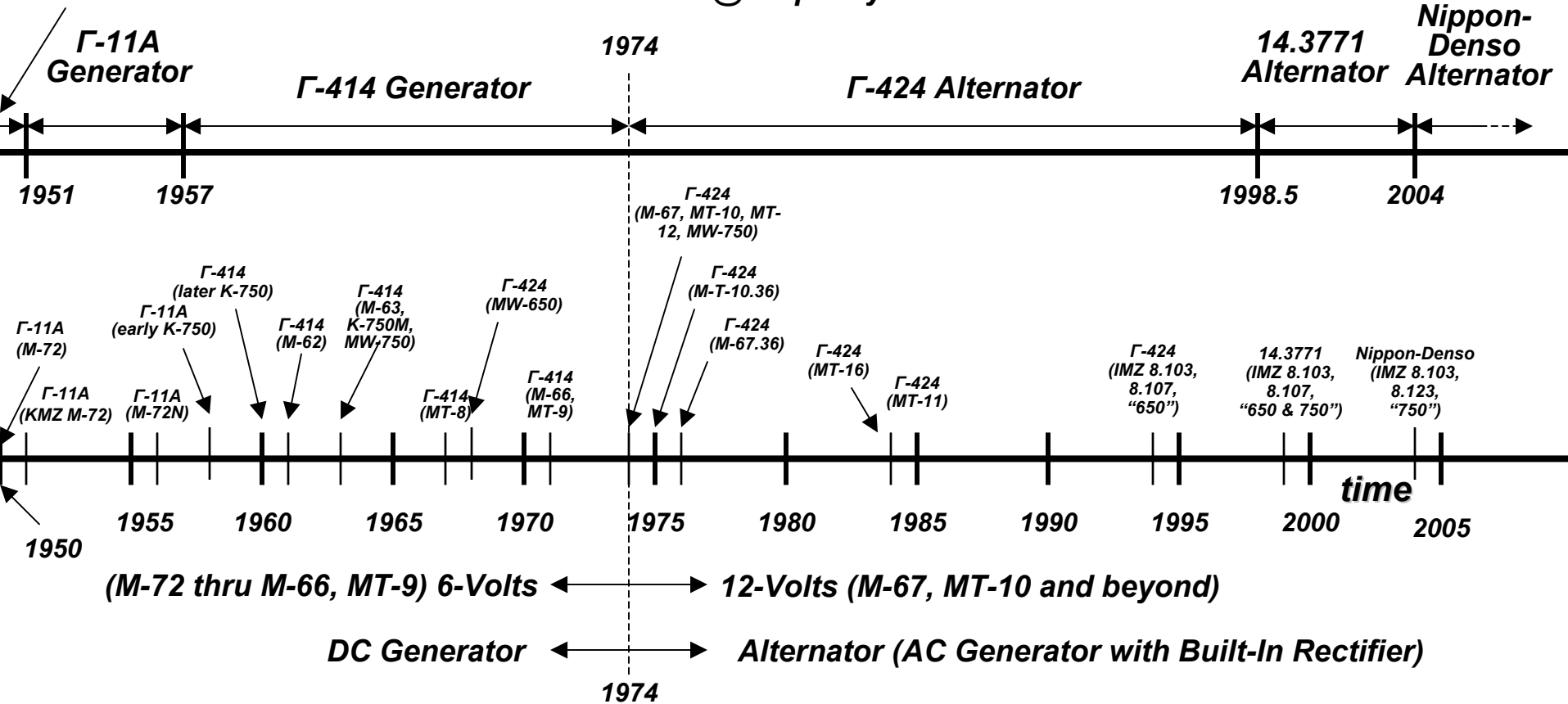

Alternators have progressed in output voltage and power, from the Г-11 (G-11) generator of 6-Volts/45-Watts in 1941, the Г-11A in 1952, the Г-414 of 6-Volts/65-Watt in 1957, the Г-424 of 12-Volts/150-Watts in 1974, the 14.3771 of 12-Volts/500-Watts in 1998.5, to the present-day Nippon-Denso alternator of 12-Volts/770-Watts.

Г-414 (G-414) 6-Volt Generator (1957-1974)

- 6-Volt / 10-Ampere / 65-Watt DC Generator
- Used on;
 - Ural: M-62, -63 & -66
 - Dnepr: K-650, later K-750, K-750M, MW-750, MW-750M, MT-8, -9 & -12
- Negative-Ground Case (Frame)
- Works in Conjunction with PP-302 / -302A Regulator
- Rotation Speed for 6.5-Volt Output
 - Zero Load: 1,350 rpm
 - Full Load (10-Amps): 1,950 rpm

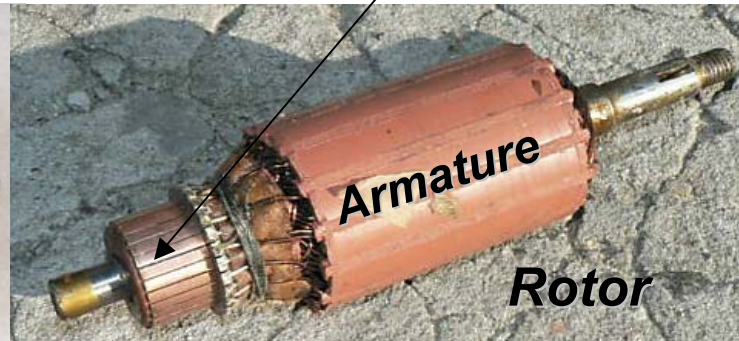
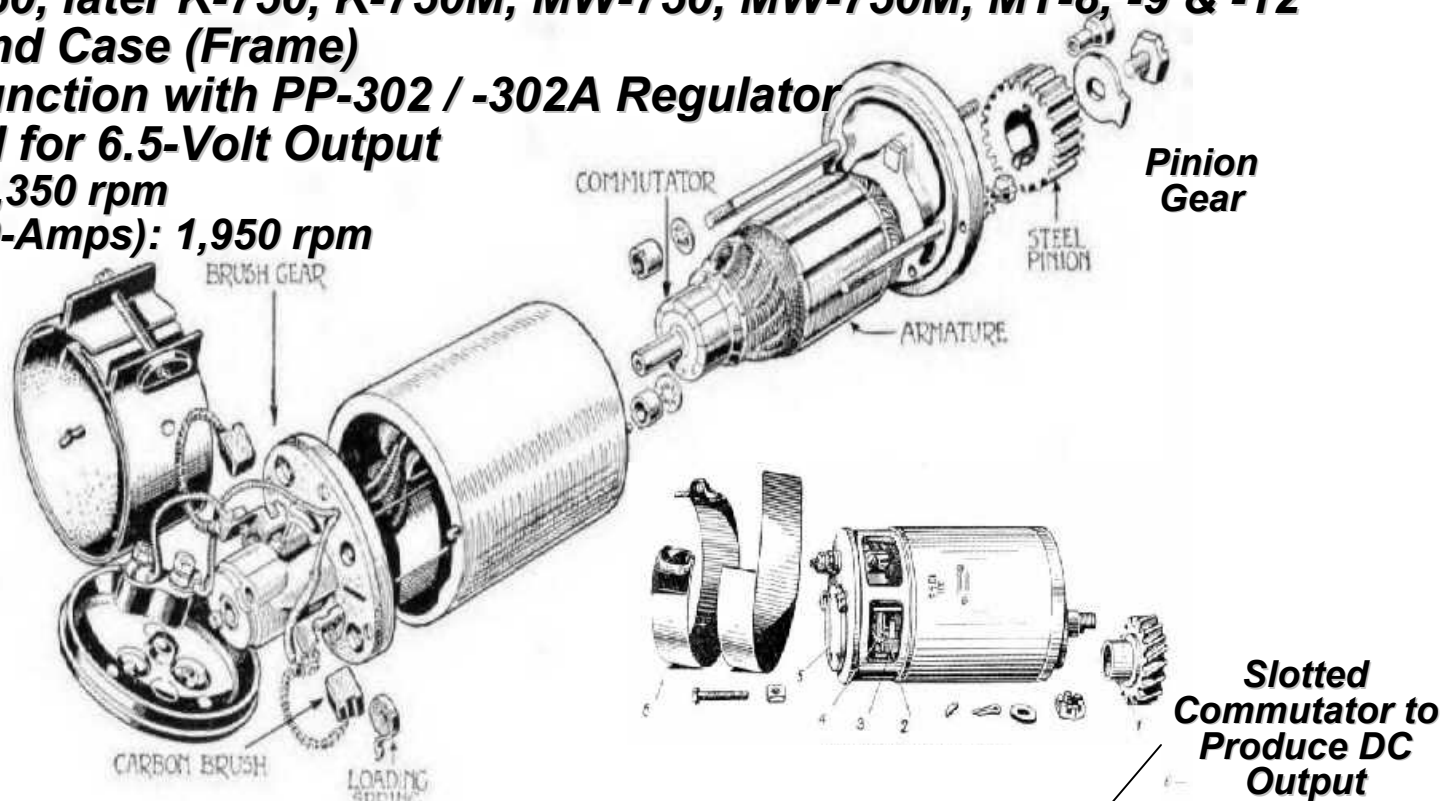

6-Volt PP-302 / -302A Regulator

- Operates in Conjunction with Г-414 Generator
- Current & Voltage Regulator with Two Elements:
 - Reverse-Current Relay
 - Cut-In Voltage of Reverse-Current Relay: 6.0 -to- 6.6-V
 - Reverse Current for Cut-Off Reverse-Current Relay: 0.5 -to- 3.5-A
 - Voltage Regulator Relay
 - Regulated Voltage @3,500 rpm Generator Speed
 - Load Current 10-Amp: 6.5 -to- 7.0-Volts
 - Load Current 0-Amp: < 8 V

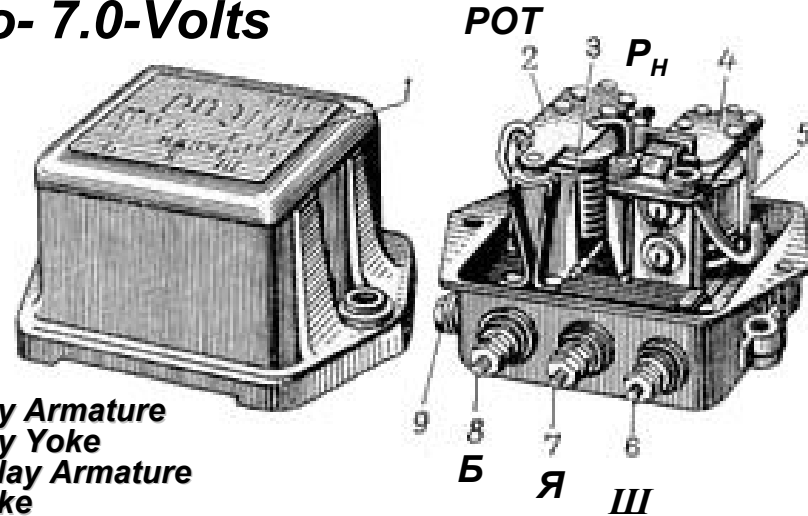

- 1 - Cover
- 2 - Reverse-Current Relay Armature
- 3 - Reverse-Current Relay Yoke
- 4 - Voltage-Regulator Relay Armature
- 5 - Voltage-Regulator Yoke
- 6 - Terminal: Ш (W) Exciter
- 7 - Terminal: Я Output
- 8 - Terminal: Б (E) Battery
- 9 - Terminal: Ground

The PP-302 maintains a constant supply voltage by controlling stator exciter (magnetic field) current from terminal Ш.

PP-302 Voltage Regulator Application

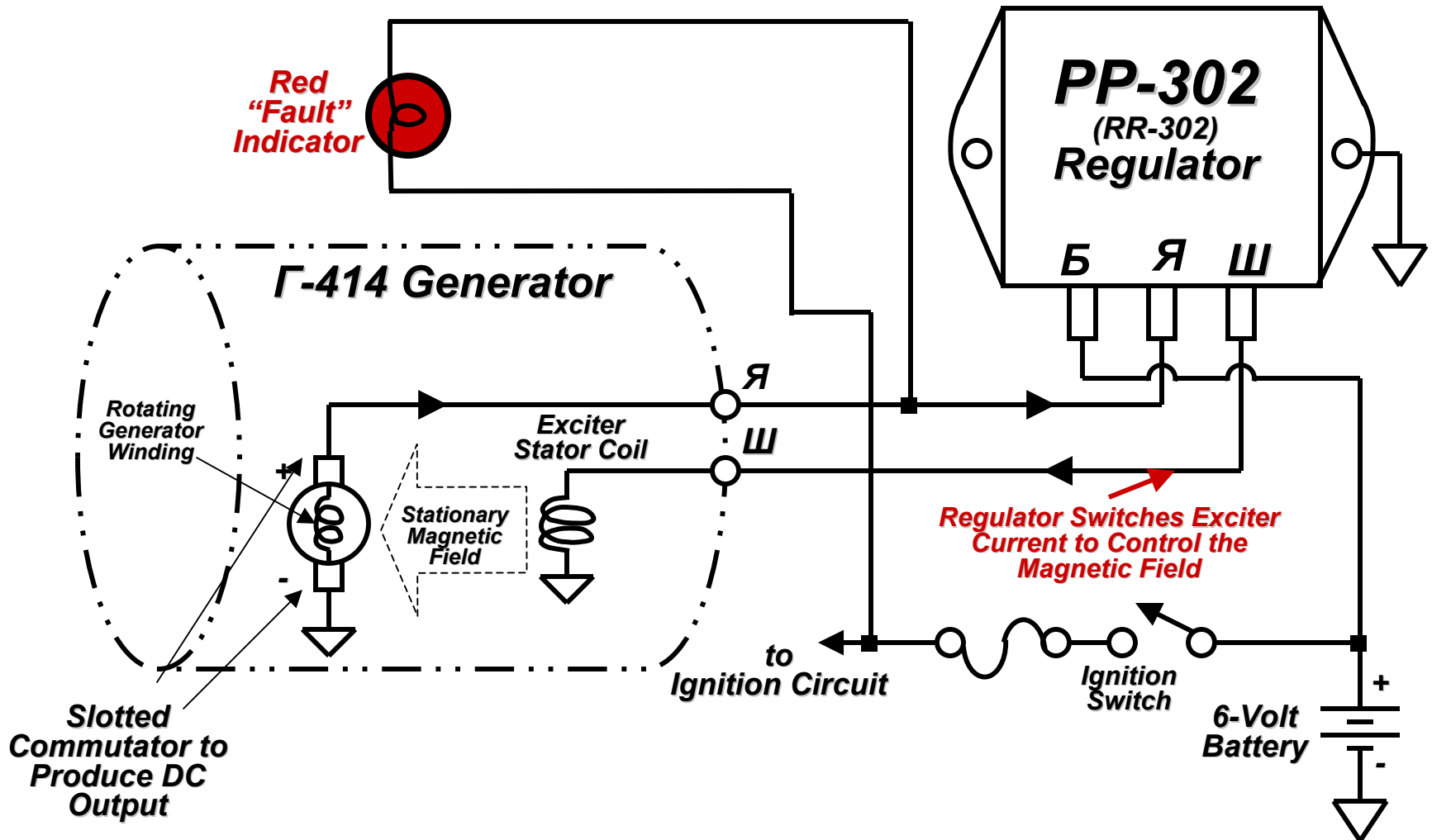

Russian generators differ from alternators in that the magnetic (exciter) field is stationary and the generator windings are rotated. The output at the commutator is DC.

PP-302 Operation

Reverse-Current Relay
(POT)

Voltage-Regulator Relay
(P_H)

Ground (mass)

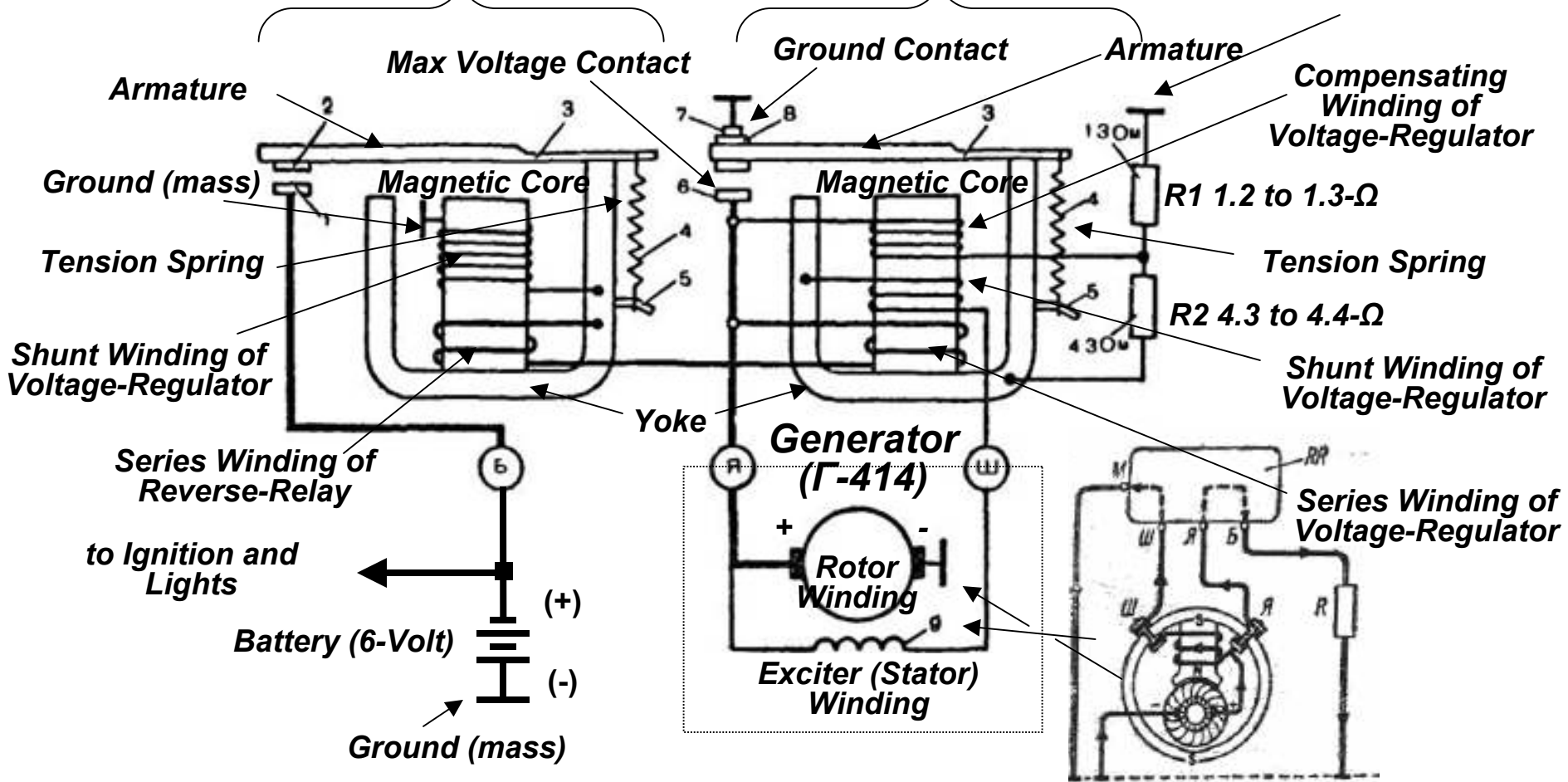

The open gap between the magnetic core and the armature (3) of the Reverse-Current Relay should be 0.6-0.8 mm. The gap between contacts 1 and 2 should be greater than 0.25 mm. The gap between the armature (3) and the Voltage Regulator core in the closed (un-energized) position should be 0.9-1.0 mm. The gap between contacts 6 and 8 should be greater than 0.25 mm.

PP-302 Regulator Operation

- **Reverse-Current Relay (POT) Has Two Positions:**
 - **1. Armature Normally-Open: Contact 1 Disconnected from Battery**
 - **Non-Charging Position**
 - **Non-Energized or Large Shunt Winding Current**
 - **Spring Tension Greater than Exciter Current (Non-Energized or Charged Battery)**
 - **Direction of Series Winding Current Changed to Repel Armature : Battery Voltage Too High (>8-Volts)**
 - **2. Armature Closed: Contact 1 Connected to Battery**
 - **Charging Position**
 - **Exciter Current Greater than Tension Spring (>0.5-Amps)**
- **Voltage-Regulator Relay (P_H) Armature (3) Has Three Positions:**
 - **1. Armature Normally-Closed: Contact 8 to Contact 7 (Ground)**
 - **Non-Energized**
 - **2. Armature in the Middle Position: Between Contacts 6 and 7**
 - **3. Armature Open: Contact 8 Connected to Contact 6 (Generator)**

PP-302 connects the generator to the battery when the exciter current is greater than 0.5-Amps. It disconnects when the generator voltage is too high (>8-Volts).

PP-302 Regulator Operation (continued)

- **Ignition On / Engine Off:**
 - **Battery Not Connected to Generator thru Reverse-Current Relay**
 - **Battery Voltage Should Be 6 -to- 6.3-Volts**
 - **Generator Exciter Coil Current Passes from Brush "+" of the Generator Rotor Winding, thru Exciter Winding, thru Shunt Winding (Voltage-Regulator Relay P_H un-energized), thru Relay Yoke, thru Armature 3, thru Contact 7-8 to Ground**
 - **Voltage Starts to Build Based on Residual Magnetic Field in Stator**
- **Engine On:**
 - **Fast Idle: Voltage Should Be 7.4 –to- 8.1-Volts**
 - **In Middle Position: Current in Excitation Coil Goes from "+" of Generator, thru Excitation Coil, thru Voltage-Regulator Relay Shunt Winding, thru Yoke, thru Series Resistors ($R1+R2$), to Ground**
 - **Two Resistors Decrease Exciter Coil Current, Yielding Reduced Generated Voltage, which Decrease Armature Attraction to Regulator Core**
 - **Armature Position Continues Until Core Magnetization Opens Armature Tension Spring Pulls Armature to Close Contact 8 Back to Contact 1**
- **As Generator Revolutions (rpm) Increase:**
 - **Armature Breaks Contacts 7 and 8 of Voltage-Regulator Relay, Leading to Voltage Fluctuations at Generator Terminals**
 - **When Armature Goes to Contact 6, Exciter Coil Current Is Off**
 - **Cycle Continues with Regulator Armature Oscillating between Contacts**
- **When Exciter Current is Large:**
 - **Pulls Reverse-Current Relay Armature (3) Down, Overcoming Tension Spring, and Connects Generator Directly Charge Battery**

Annually, take the cover off and give it a spray with WD-40.

Ural (Урал) M-52, M-61 and M-72K, M-72M with PP-302 Regulator

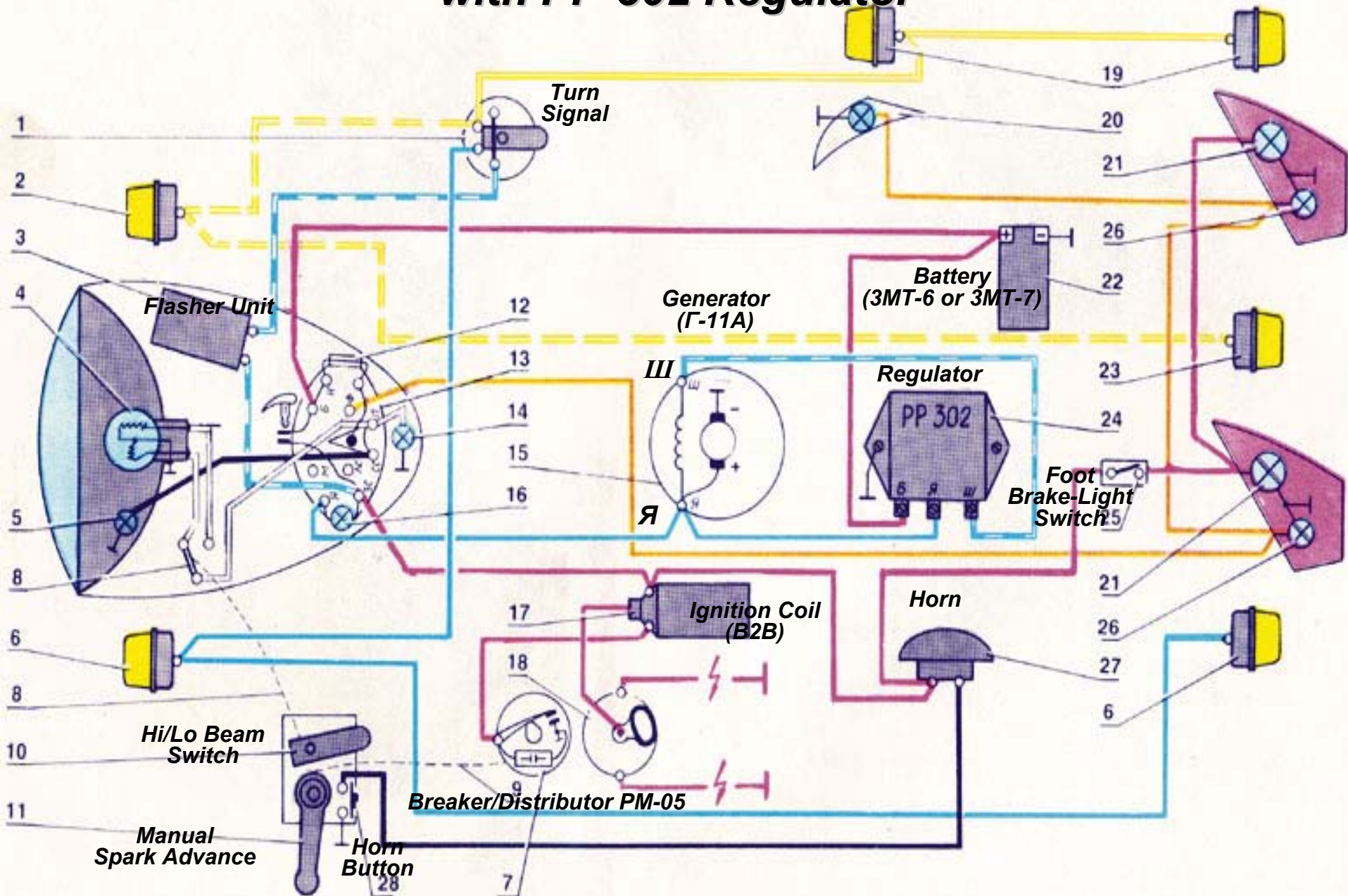

Ural (Урал) M-62, M-63 (Ural-2) and M-66 (Ural-3) and Днепр (Днепр) K-650, MT-9

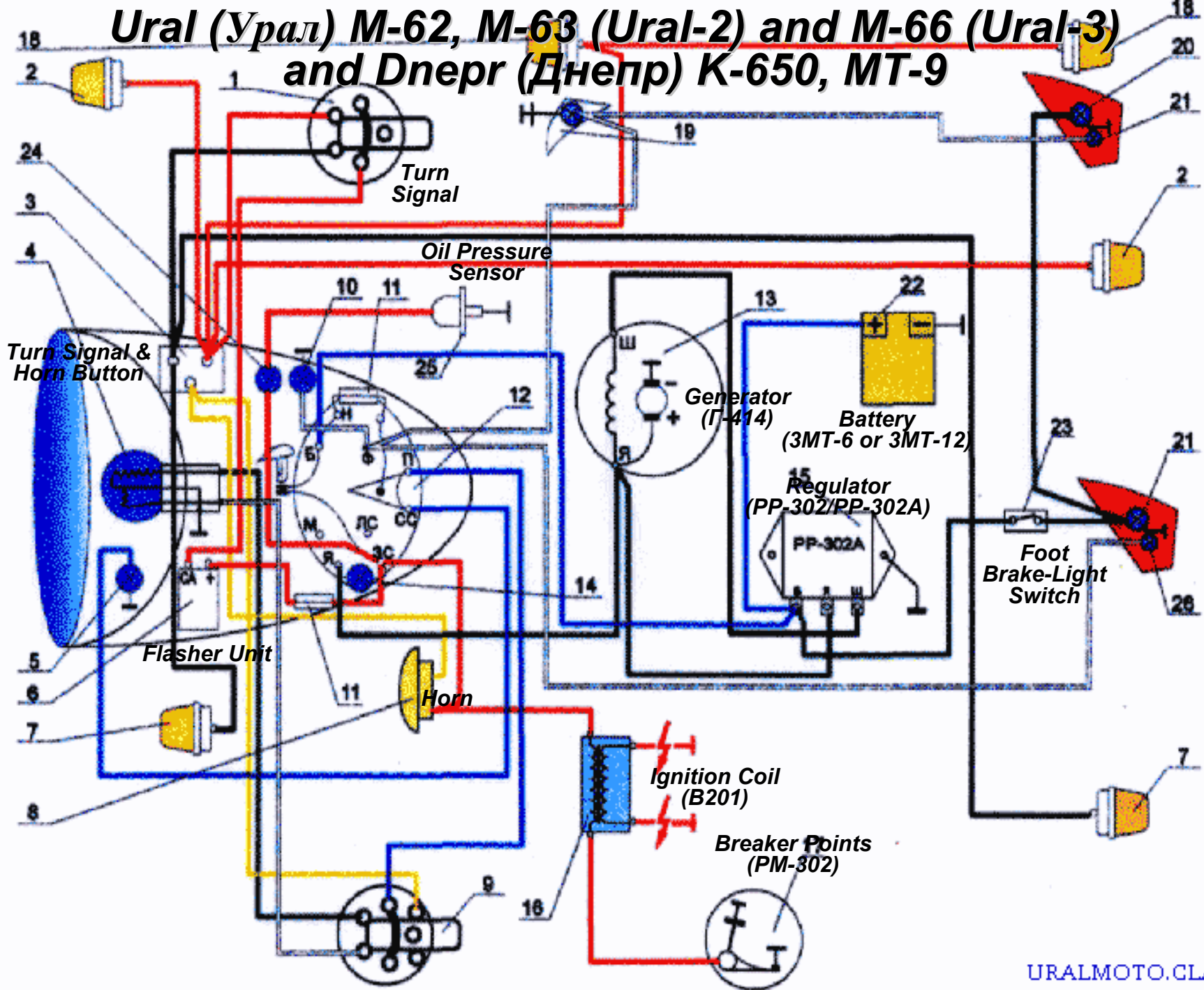

Днепр (Днепр) K-750, K-750M and MT-12

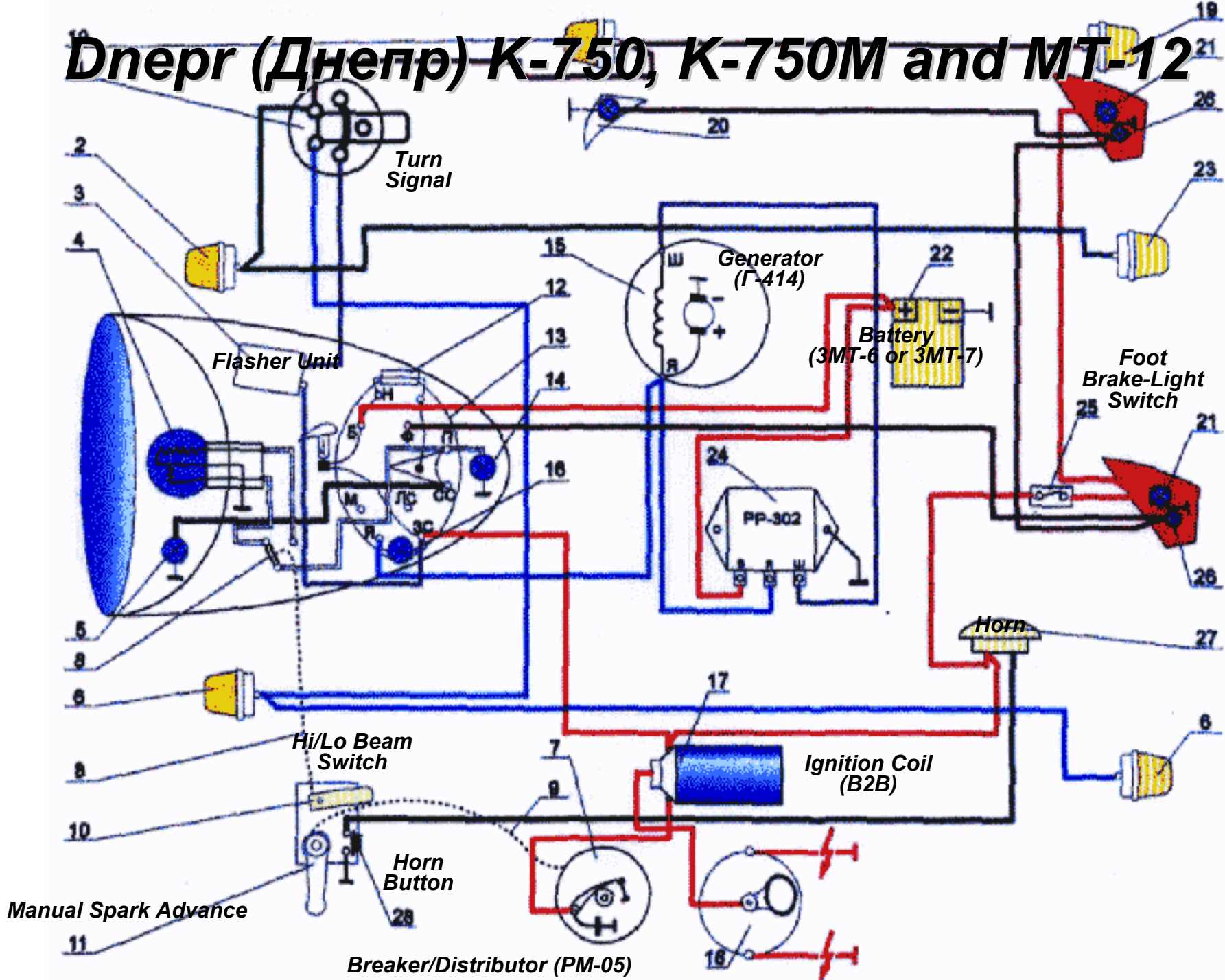

Dnepr (Днепр) Early K-650 and MT-9

with PM-05 Breaker/Distributor and B2B Ignition Coil

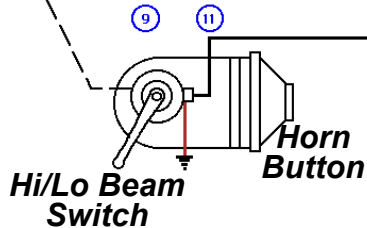
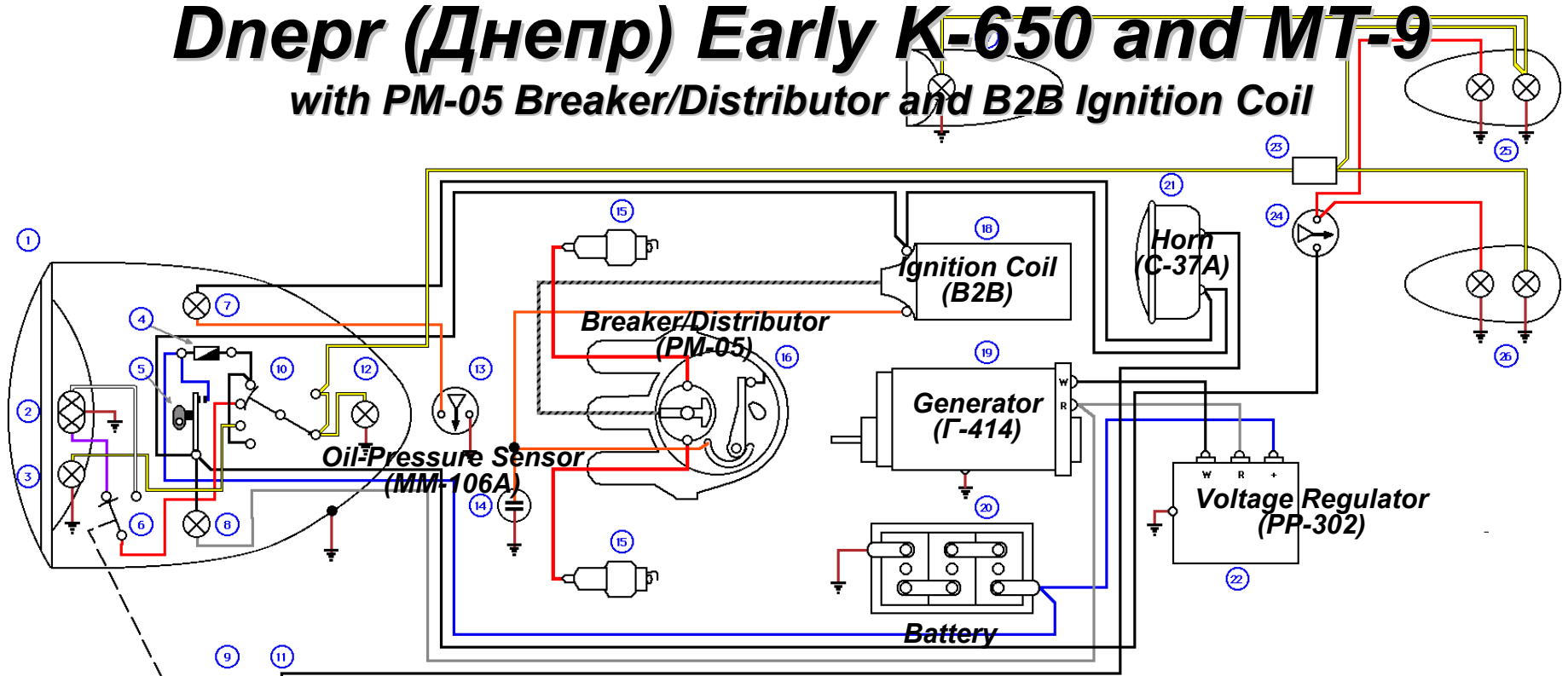

- | | | | |
|-----------------------------------|--------------|-----------------|---------|
| 1. Head lamp/Dash | | | |
| 2. High and low beam | | bulb A6-32 + 32 | |
| 3. parking light | | bulb A6-2 | |
| 4. Fuse | | | |
| 5. Key | | | |
| 6. dimmer switch | | | |
| 7. Oil pressure indicator | A6-1 | | |
| 8. Generator charge indicator | lamp A6-0.25 | | |
| 9. Mechanical dimmer switch lever | | | |
| 10. Primary switch | | | |
| 11. horn button | | | |
| 12. speedometer bulb | | | |
| 13. Oil pressure switch | | | |
| 14. Condensor | | | |
| 15. Spark plugs A8Y | | | |
| 16. Points and distributor | | | |
| 17. Front side car fender light | | | |
| 18. Ignition coil | | | |
| 19. DC Generator | | | |
| 20. Battery | | | |
| 21. Horn | | | |
| 22. Regulator | | | 3-MT-12 |
| 23. Connector | | | C37A |
| 24. Stop light switch | | | BK854 |
| 25. Rear side car fender light | | | |
| 26. Rear light | | | |

1968 K-650, Dnepr MT-9