



***Russian Regulators: Part III  
Mechanical Relay-Type PP-330  
for the  
11-Amp Г-424 Alternator***

***Ernie Franke  
eaf Franke@tampabay.rr.com***

# **12-Volt Electro-Magnetic (Relay-Type) Regulator (PP-330) for the Г-424 11-Amp Alternator**

## **• Background**

- Voltage Regulators Paired with Specific Generators/Alternators**
- Time-Line for Generators/Alternators/Regulators**
- Г-424 Alternator Performance**
- Specs for the Г-424 Alternator**
- Alternator Application in Ural (M-67, -67.3 and “650cc” Series) / Dnepr (MT-10, -11, and -16) Wiring**

## **• What Is the PP-330?**

- External Voltage Regulator for 11-Amp Г-424 Alternator**
- Electro-Magnetic (Relay-Type) Design**
- Years of Application: 1974 -to- 1992**
- Upgraded to 12-Volts from 6-Volt PP-302 Regulator**
- Later Superseded by Solid-State (Electronic) 33.3702 Regulator in 1992**

## **• How Does It Work?**

- Regulates Alternator Output Voltage to 14-Volts**
- Supplies Exciter Current to Vary Magnetic Field in Rotor**
- Provides Constant Voltage Regardless of Rotor Speed and Load**

## **• Circuit Description and Operation**

## **• Replacement**

- Replacement Purchased On-Line**

**The Relay-Regulator (PP-330, a.k.a RR-330) was the first 12-Volt regulator used on a Russian motorcycle (Ural M-67 and Dnepr MT-10).**

# Types of Generators/Alternators for Ural (Урал) and Dnepr (Днепр) (01/10)

eafranke@tampabay.rr.com

Generator/ Alternator	Type	Vintage	Nominal Voltage	Current	Nominal Power	Regulator	Motorcycles	
							Ural(IMZ)	Dnepr (KMZ)
<b>Г-11</b> (G-11) (P/N: 72181)	<b>DC</b> Generator	<b>1941-</b> <b>1951</b>	<b>6-Volt</b> (7-Volt)	<b>7-Amp</b>	<b>45-Watts</b>	<b>PP-1</b> <b>PP-31 (1950)</b>	<b>M-72</b>	<b>Not Used</b>
<b>Г-11А</b> (G-11A) (P/N: 72181-A)	<b>DC</b> Generator	<b>1952-</b> <b>1957</b>	<b>6-Volt</b> (7-Volt)	<b>7-Amp</b>	<b>45-Watts</b>	<b>PP-31 (1950)</b> <b>PP-31A (1956)</b>	<b>M-72, M-72M,</b> <b>M-61</b>	<b>M-72, M-72N,</b> <b>early K-750</b>
<b>Г-414</b> (G-414) (P/N: 750181)	<b>DC</b> Generator	<b>1957-</b> <b>1974</b>	<b>6-Volt</b> (7-Volt)	<b>10-Amp</b>	<b>65-Watts</b>	<b>PP-31A (1956)</b> <b>PP-302 (1963)</b> <b>PP-302A</b>	<b>M-62, M-63,</b> <b>M-66</b>	<b>K-650, later K-750,</b> <b>K-750M, MW-750,</b> <b>MW-750M, MT-8,</b> <b>MT-9, MT-12</b>
<b>Г-424</b> (G-424) (P/N: 3701000)	<b>Alternator</b> (Built-in Rectifier)	<b>1974-</b> <b>1998</b>	<b>12-Volt</b> (14-Volt)	<b>11-Amp</b> (aka 14-A)	<b>150-Watts</b>	<b>PP-330</b> <b>33.3702 (1992)</b>	<b>M-67, M67.36,</b> <b>IMZ 8.103 Series</b>	<b>MW-650, MW-650M,</b> <b>MT-10, MT-10.36,</b> <b>MT-11, MT-14, MT-16</b>
<b>Hitachi</b> (Limited Appearance)	<b>Alternator/</b> <b>Starter</b>	<b>1998-</b> <b>1998.5</b>	<b>12-Volt</b> (14-Volt)	<b>18-Amp</b>	<b>300-Watts</b>	<b>Internal to</b> <b>Alternator??</b>	<b>IMZ 8.103 and</b> <b>8.107</b> <b>"650" Series</b>	<b>Not Used</b>
<b>14.3771</b> (P/N: 14.3771- 010)	<b>Alternator</b> (Built-in Rectifier & Regulator)	<b>1998.5</b> <b>-2004</b>	<b>12-Volt</b> (14-Volt)	<b>35-Amp</b>	<b>500-Watts</b> (aka 350-W)	<b>Internal to</b> <b>Alternator</b> <b>(YA212A11E)</b>	<b>IMZ 8.103, 8.103X,</b> <b>8.123, 8.123X</b> <b>"650 &amp; 750" Series</b>	<b>Not Used</b>
<b>Nippon</b> <b>Denso</b> (P/N: IMZ-8.1037- 18092)	<b>Alternator</b> (Built-in Rectifier & Regulator)	<b>2004-</b> <b>present</b>	<b>12-Volt</b> (14-Volt)	<b>55-Amp</b>	<b>770-Watts</b>	<b>Internal to</b> <b>Alternator</b> <b>(126000-0600)</b>	<b>IMZ 8.103, 8.103X,</b> <b>8.123, 8.123X</b> <b>"750" Series</b>	<b>Not Used</b>

## Notes:

- Nomenclature: The Cyrillic letter "Г" transliterates (Russian-to-Latin) to "G" or "L" or "T." Thus we see Г-414 or G-414 or L-414 or T-414, all for the same part.**
- Cannot use Alternator with discharged battery or without battery.**



# Ural (Урал) - Днепр (Днепр) Generator/Alternator Time-Line (12/09)

eafranke@tampabay.rr.com

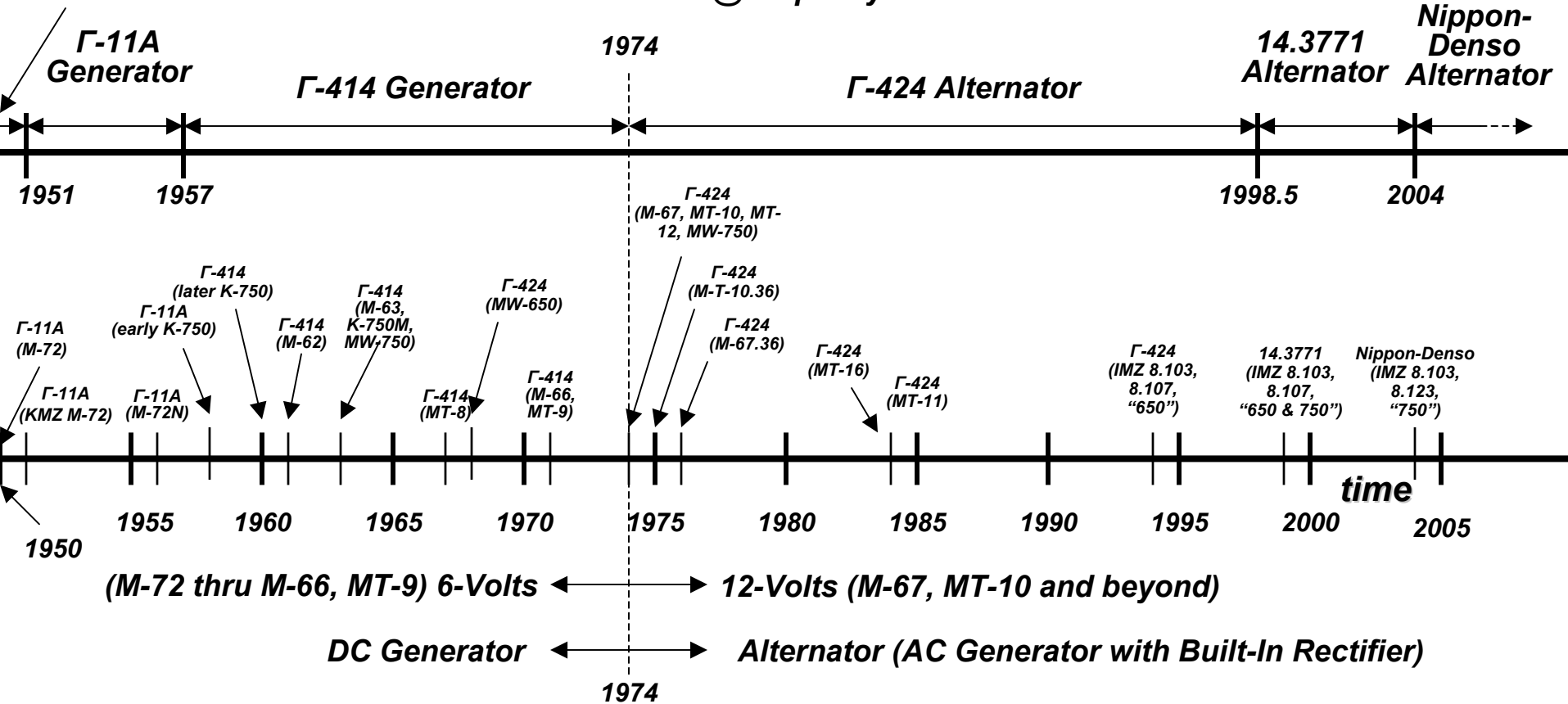

**Alternators have progressed in output voltage and power, from the Г-11 (G-11) generator of 6-Volts/45-Watts in 1941, the Г-11A in 1952, the Г-414 of 6-Volts/65-Watt in 1957, the Г-424 of 12-Volts/150-Watts in 1974, the 14.3771 of 12-Volts/500-Watts in 1998.5, to the present-day Nippon-Denso alternator of 12-Volts/770-Watts.**

# **Alternator Specification: Г-424 (G-424) (1974-1998)**

- **12-Volt / 11-Ampere / 150-Watt Alternator (a.k.a. 14-Amp)**
- **“Full-Time” (Continuous) Current Rating: 11-Amperes**
- **Alternator Г-424 Used on;**
  - **Ural: M-67, M-67.36, IMZ 8.103 Series**
  - **Dnepr: MW-650, MW-650M, MT-10, MT-10.36, MT-11, MT-14, MT-16**
- **Used with Mechanical (PP-330) & Solid-State (33.3702) Regulators**
- **3-Ø (three-phase), 12-Pole Stator Winding for Smooth Output Voltage**
- **Built-in Full-Wave Rectifier (MSF-2A)**



**The Г-424 alternator surfaced in 1974 on Ural's M-67 and Dnepr's MT-10, as Russian motorcycles migrated to 12-Volts.**

# Russian 11-Amp Г-424 Alternator

Engine (Crankshaft) Speed	Alternator (Rotor) Speed	Motorcycle Speed (mph/kmph)
Idle (900-to-1,000 rpm)	1,200 rpm -to-1,333 rpm	10 mph/16 kmph
2,500 rpm	3,333 rpm	25 mph/40 kmph
3,500 rpm	4,667 rpm	40 mph/65 kmph

Current Generated by Alternator versus Speed of Rotation of the Alternator

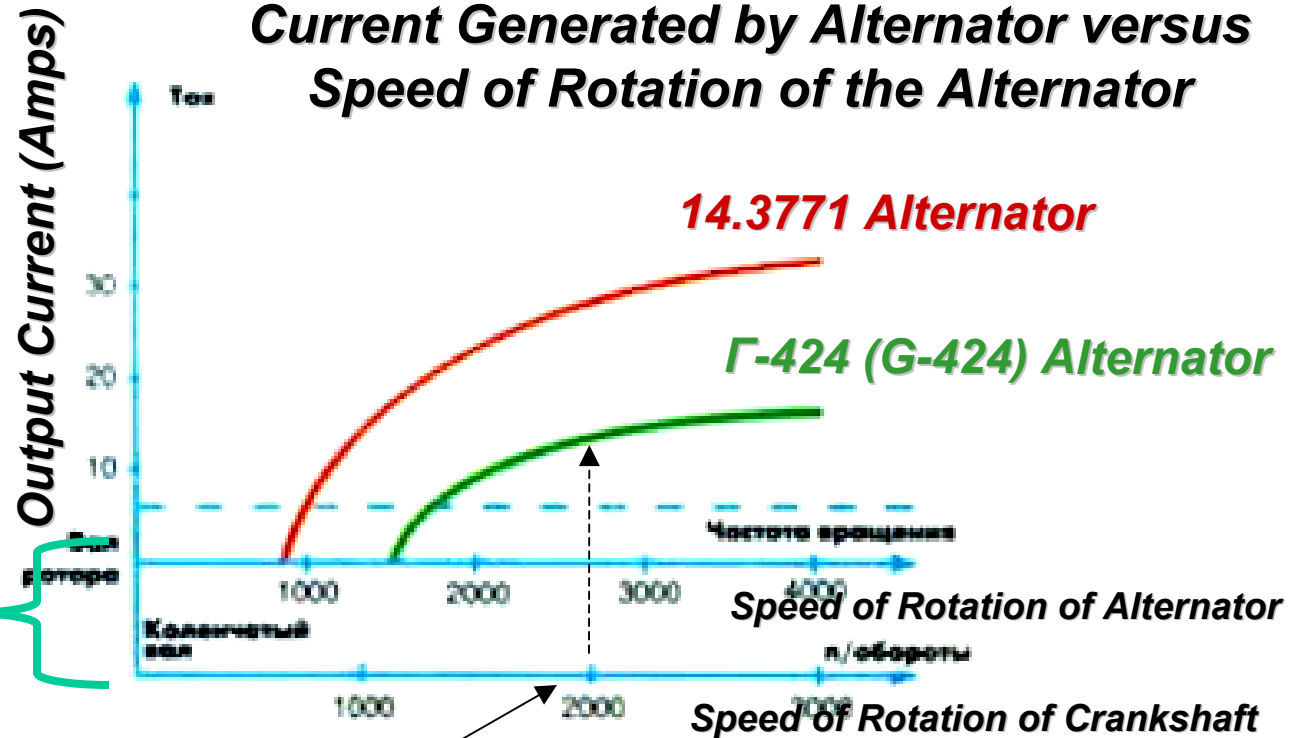

**Г-424 alternator rotor turns 1.33X crankshaft**

Crankshaft speed of Г-424 Alternator to produce Rated Current (15-to-20 mph)

Indicator light may blink when motorcycle moves at 20 mph (30 km/h) and at the instance an additional load is connected!

**The Г-424 alternator provides rated current (11-Amps) at 2,000 rpm of the crankshaft. Thus for urban driving (low-speed & traffic lights), the alternator was sufficient to supply the necessary charging current (prior to electric-start).**

# **Typical Current Consumption for $\Gamma$ -424 Alternator**

- **Typical Load Using Standard Lights and Low-Beam**
  - **Running Lights**
    - **Sidecar Front Right (A12-8 or #97): 10-Watt**
    - **Sidecar Rear Right (A12-21-3 or #1156): 21-Watts**
  - **Motorcycle Rear (A12-21-3 or # 1156): 21-Watts**
  - **Speedometer Face (A12-1 or Sylvania 3893): 4-Watts**
  - **Head-Light (A12-45+40 or H6024, 7" sealed): 40/45-Watts (Low/High)**
  - **Ignition System: 18-Watts**
  - **Total Consumption (assuming low-beam): 114-Watts (8.9-Amps)**
- **Typical Load Using Standard Lights and High-Beam**
  - **High-Beam Indicator Lamp: 4-Watts**
  - **Head-Light (A12-45+40 or H6024, 7" sealed): 45-Watts**
  - **Total Consumption (assuming high-beam): 123-Watts (9.6-Amps)**
- **Typical Load Using Halogen Head-Light**
  - **Halogen Sealed-beam (low-beam): 55-Watt**
  - **Total Consumption (assuming low-beam): 129-Watts (10.1-Amps)**

**Clearly, even prior to electric-start, the current demands are nearly equal to the output capability of the alternator.**



# PP-330: 12-Volt / 11-Amp Voltage Regulator

Top View



14-V / 11-A

ЛК (LC) ~ Ш

Bottom View

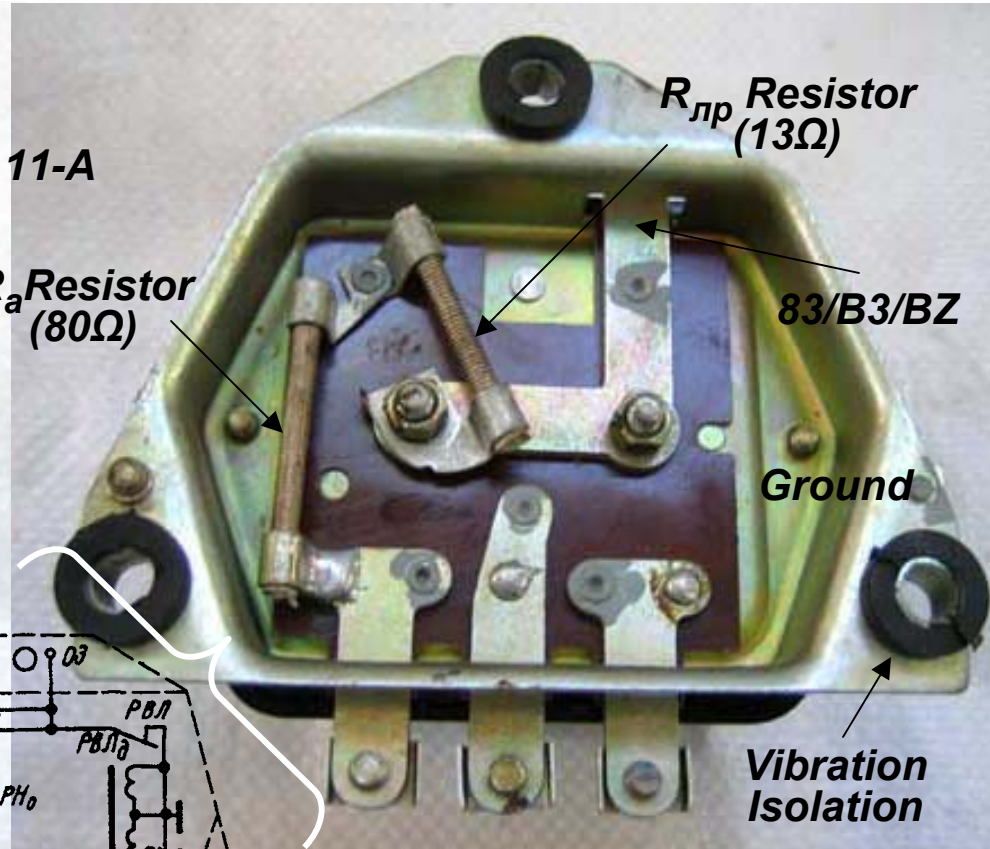

$R_{лр}$  Resistor (13Ω)

$R_a$  Resistor (80Ω)

83/B3/BZ

Ground

Vibration Isolation

Ш ~ ЛК (LC)

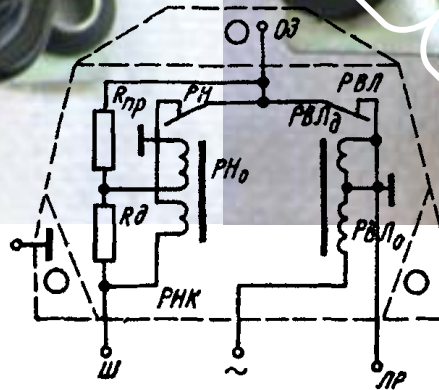

The PP-330 utilizes two electro-magnetic relays to maintain a constant output voltage from the alternator, and to control a red "alternator fault" indicator light.



# PP-330 Voltage Regulator Application

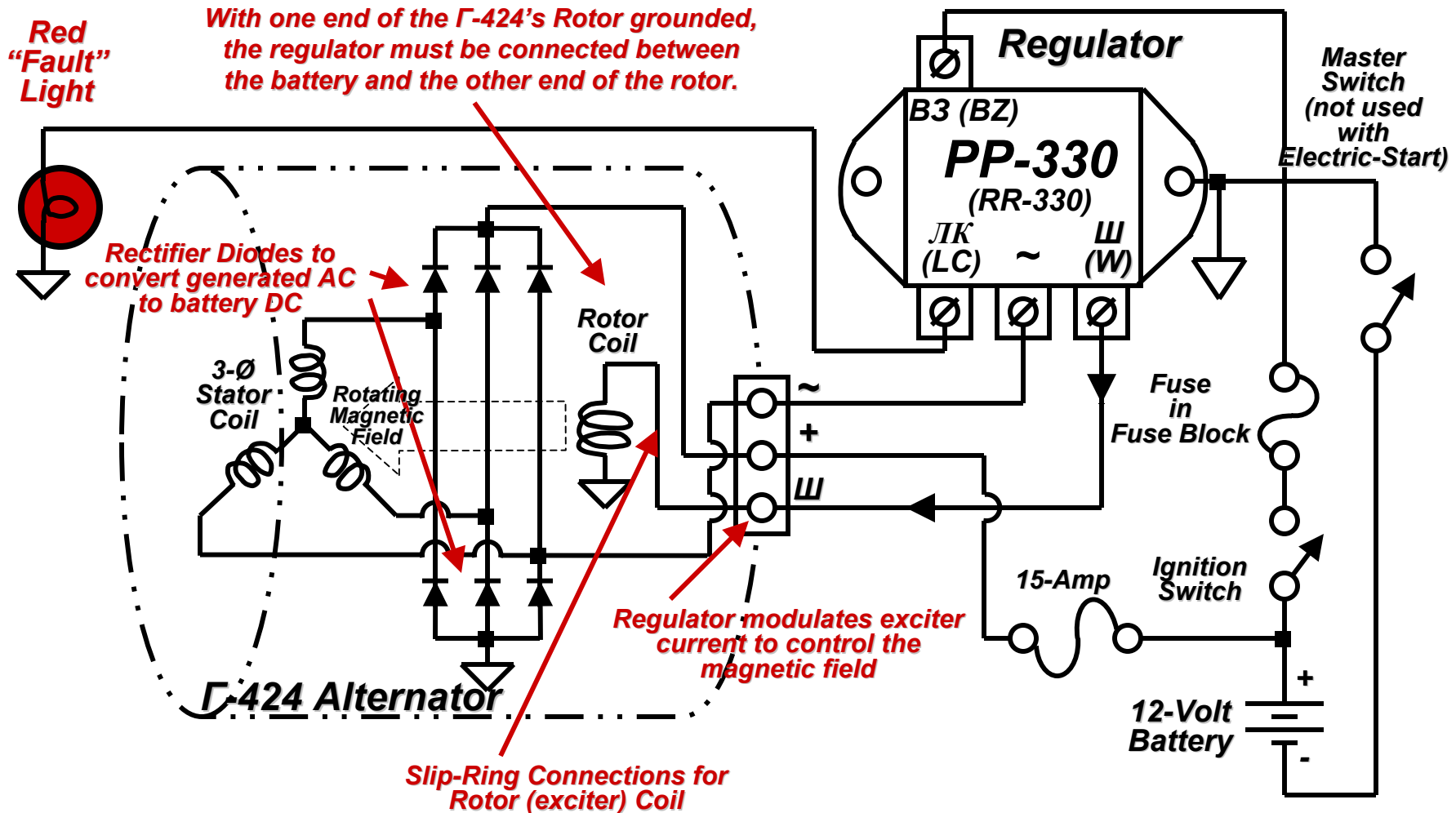

**The PP-330 voltage regulator varies the current in the rotor coil (terminal W) to maintain a constant output voltage at the "+" terminal.**

**•PP-330 Regulator Construction**

- Consists of Two Relays;
- Voltage Relay  $P_H$ : Maintains Alternator Voltage within Specified Limits (13.5-to-14.5-Volts)

Over/Under-Voltage Relay  $P_H$

- Lamp Control Relay  $P_{ВЛ}$ : Controls Red, Dash-Mounted "Fault Indicator Lamp (when extinguished, alternator is charging properly)

Lamp Control Relay  $P_{ВЛ}$

- Distinctive Feature of Alternator: Very Weak Self-Excitation. Only when Rotor Speed Exceeds 2400 rpm, Alternator Fully Self-Sufficient.

Until Then, Exciter Winding Powered from Battery.

Ignition Switch

- Caution: Alternator Cannot Stand Working without Load (breakage or disconnection of wires).

Open-Loop Voltage Capable of Destroying Rectifier Bridge.

Г-424 Alternator

- Helpful Hint: If Battery Discharged, Engine can be Started by Connecting Small Flashlight Batteries (4.5-V) "plus" to terminal W (Ш) and "minus" to Chassis Ground.

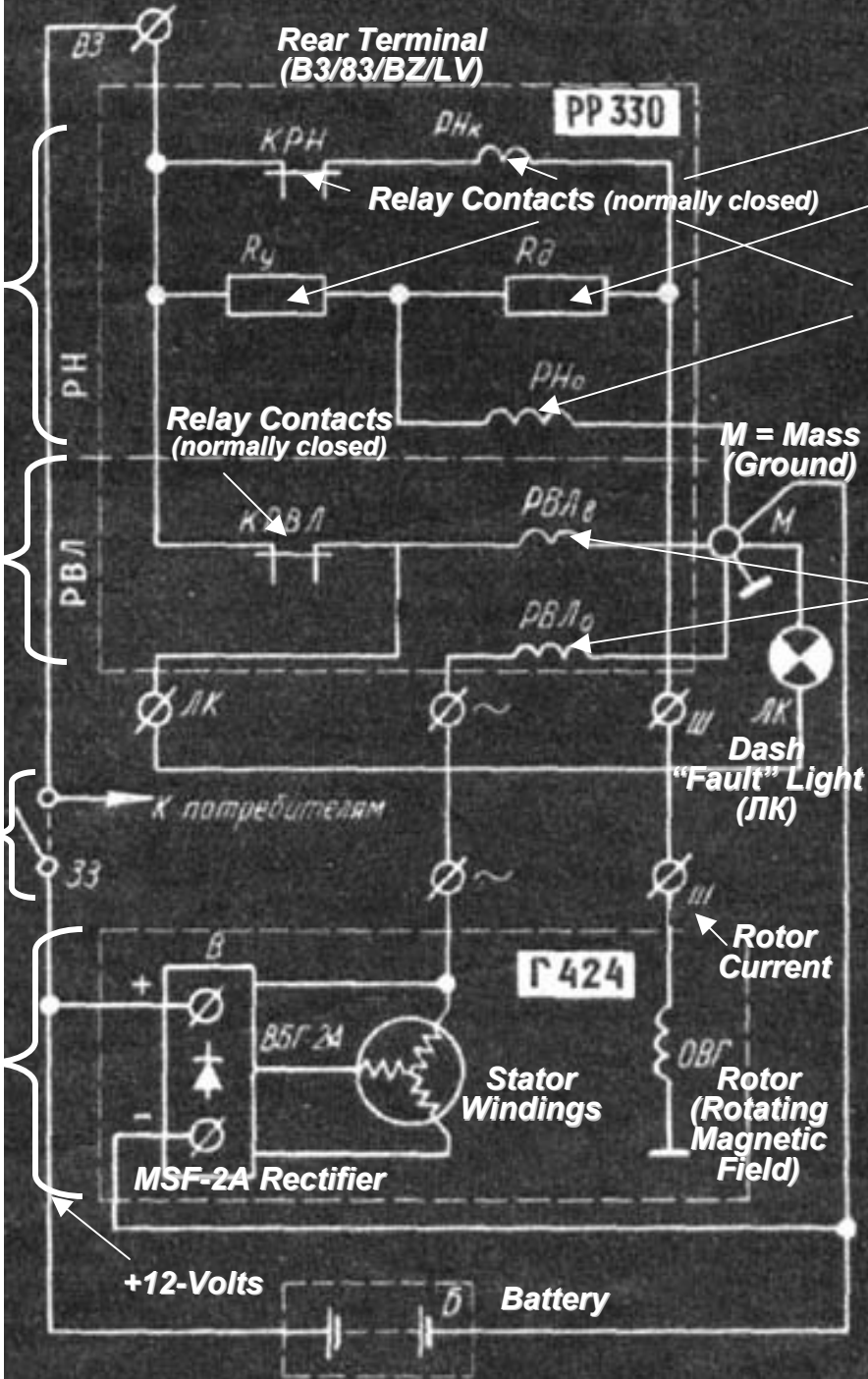

$R_{лр}$  Resistor (13  $\Omega$ )  
 $R_A$  Resistor (80  $\Omega$ )

$P_H$  Relay Coils

$P_{ВЛ}$  Relay Coils

M = Mass (Ground)

Dash "Fault" Light (ЛК)

Rotor Current

Rotor (Rotating Magnetic Field)

+12-Volts

Battery

# PP-330 Voltage Regulator Operation

- **Ignition Switch On / Engine Off:**
  - **Current from Battery thru Ignition Switch and Rear Terminal B3 (BZ) of Regulator, to Normally-Closed Relay  $P_H$  and Compensating Windings Enters Excitation (Rotor) Winding**
  - **Caution: If Ignition Off & Engine Not Running, Battery Discharge thru Rotor Winding May Overheat**
- **Ignition Switch On / Engine On - Idle:**
  - **As Rotor Speed Increases, Terminal Voltage Increases**
  - **When Voltage Reaches 13.5-to-14.5-Volts, Magnetic Forces Generated in Core Exceed Armature Spring Tension, Opening Relay Contacts**
  - **Exciter Winding Current Now Flows Thru Two Series Resistors, thereby Reducing Current and Consequently the Alternator Terminal Voltage**
  - **Electro-magnetic Force Decreases on the Armature and Spring Closes Contacts**
  - **Current Entering Winding Excitation Increases, Increasing the Alternator Terminal Voltage, thus, Turning On and Off the Charging Current**
- **Lamp Control Relay -  $P_{ВЛ}$** 
  - **Connected to Alternator Terminal "~" phase**
  - **When Ignition On**
    - **Current from Battery thru Normally-Closed Relay  $P_{ВЛ}$  Contacts**
    - **Current Flows to Light "Fault" Indicator**
  - **When Alternator Output Voltage Exceeds Battery Voltage**
    - **Relay Pulls In and Opens Contacts**
    - **Lamp Goes Out**

**Relay-Regulator PP-330 consists of two relays; voltage relay  $P_H$  and lamp control relay  $P_{ВЛ}$ .**



# Application of PP-330 Voltage Regulator with Г-424 Alternator

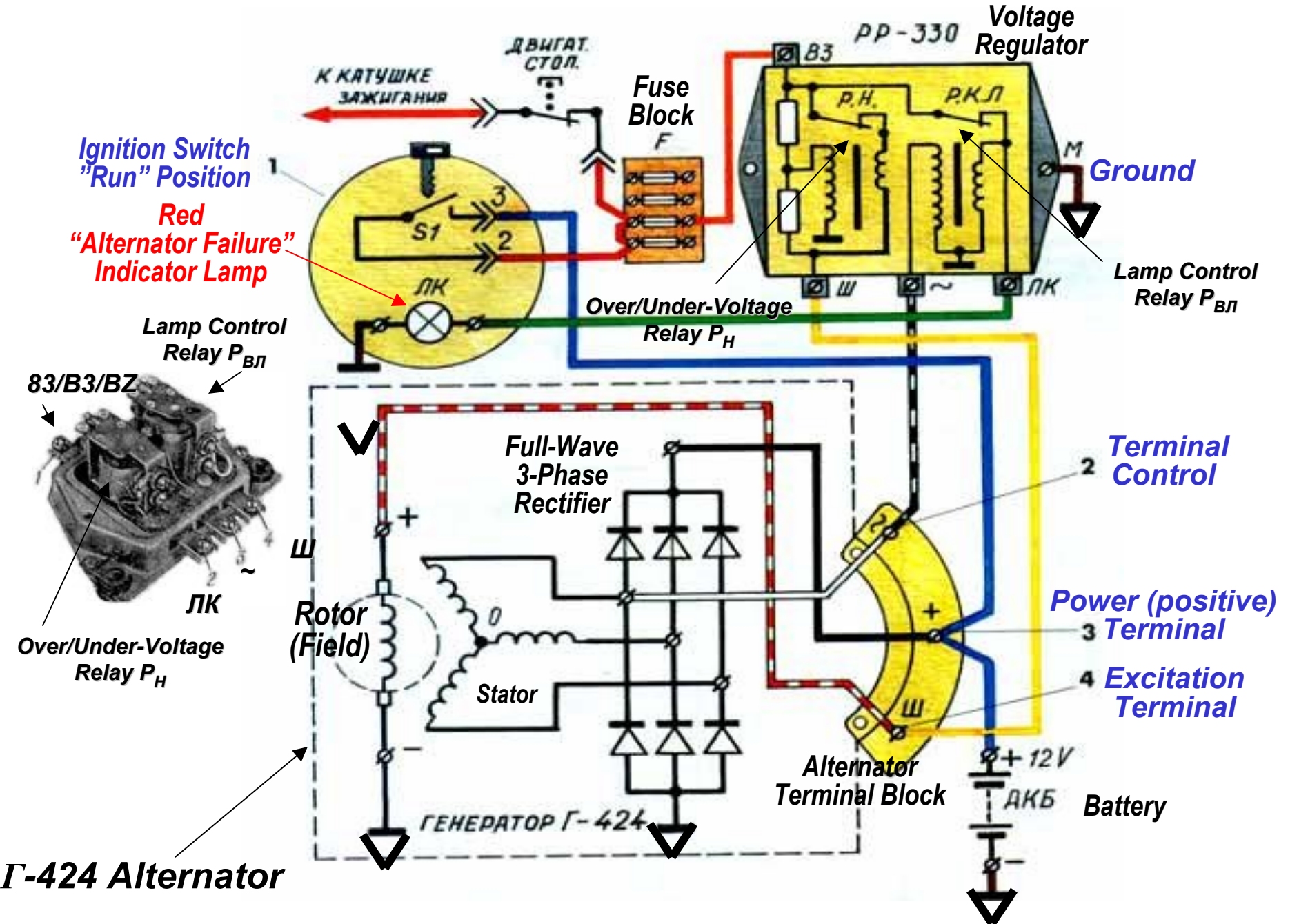

# Ural (Урал) M-67 and M-67.36

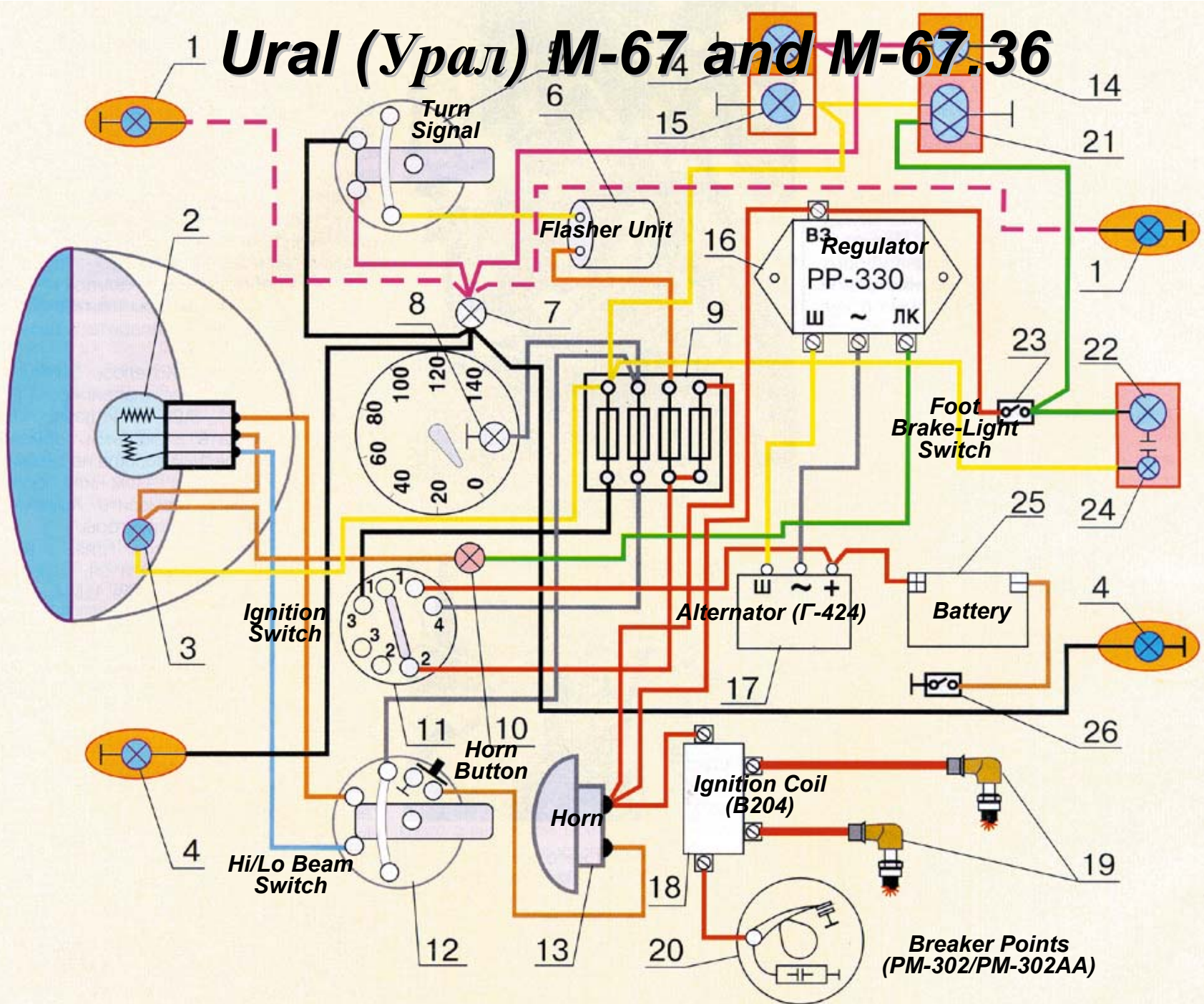



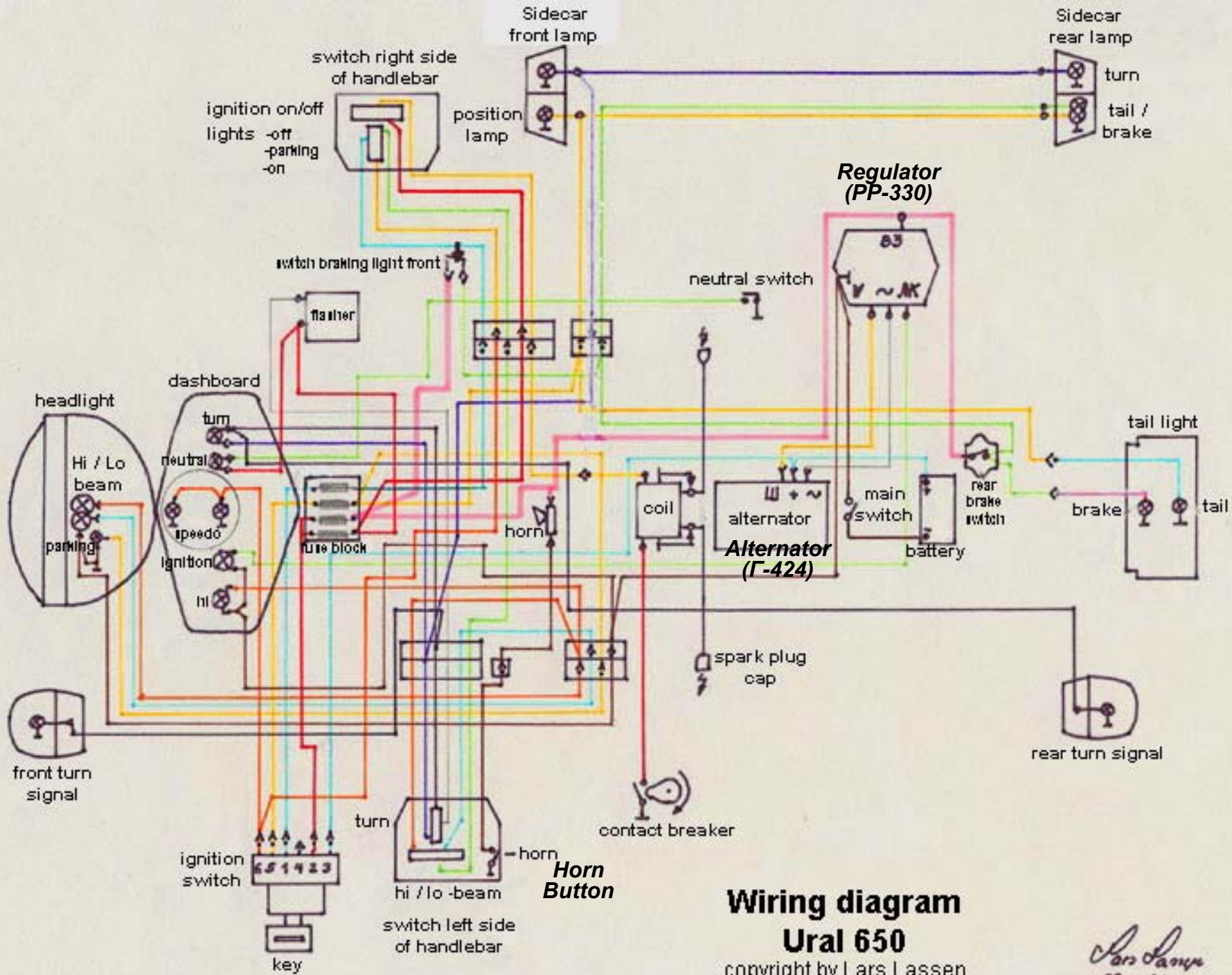

**Wiring diagram**  
**Ural 650**  
 copyright by Lars Lassen

*Lars Lassen*  
 29.12.93



# Днепр (Днепр) МТ-10 (1974)

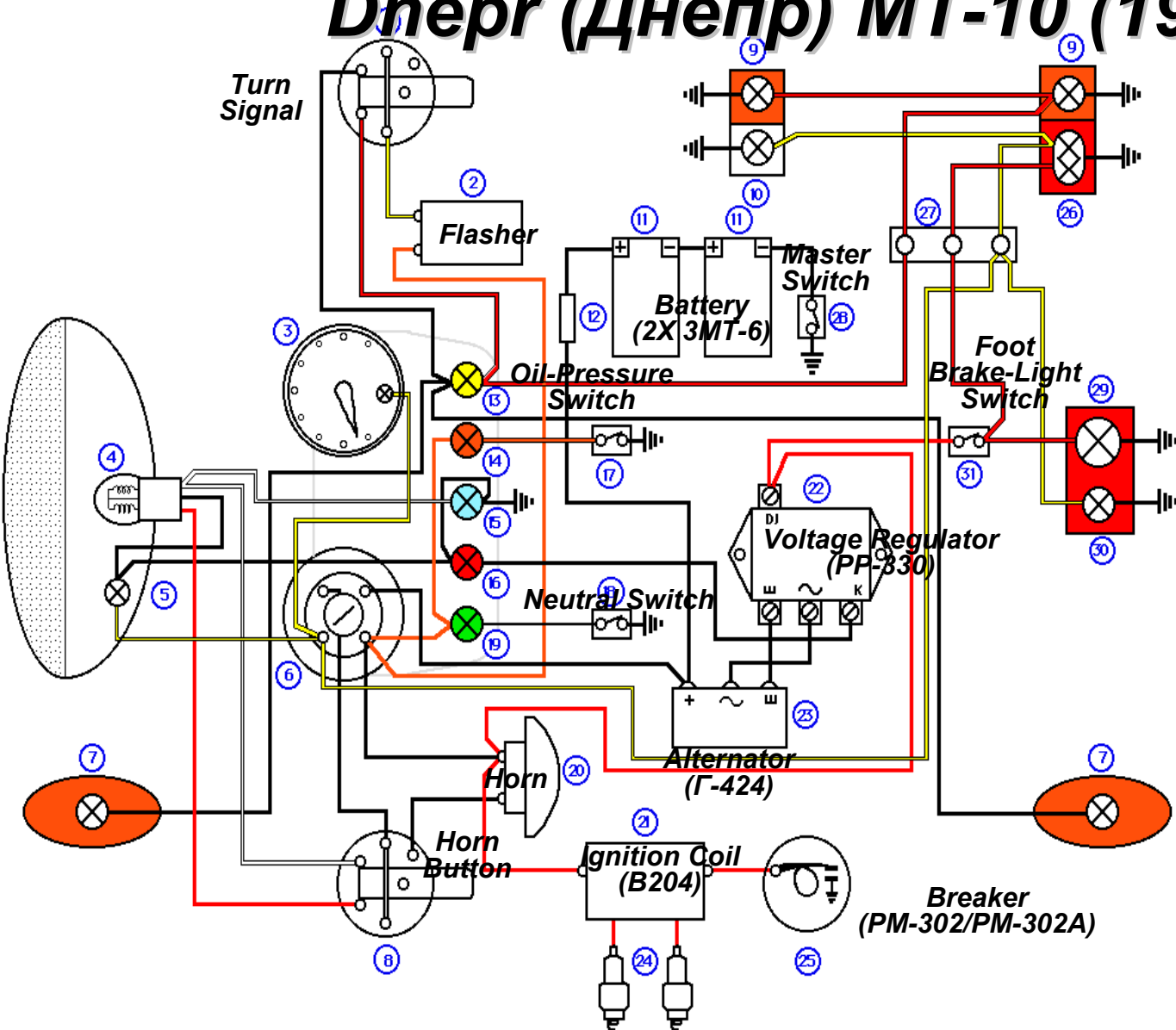

- 1. Turn Signal Switch
- 2. Turn Signal Flasher
- 3. Instrument Illumination
- 4. Headlight
- 5. Parking light
- 6. Ignition Switch
- 7. Front Left Turn Signal – Bike
- 8. High Beam Switch
- 9. Right Turn Signal – Sidecar
- 10. Front Right Turn Signal – Bike
- 11. Battery
- 12. Fuse
- 13. Turn Signal Indicator
- 14. Oil Pressure Indicator
- 15. High Beam Indicator
- 16. Charge Indicator
- 17. Oil Pressure Switch
- 18. Neutral Switch
- 19. Neutral Indicator
- 20. Horn
- 21. Coil
- 22. Voltage Regulator
- 23. Generator
- 24. Sparkplugs
- 25. Points/Contact Breaker
- 26. Rear Right Turn Signal – Bike
- 27. Wire Connector
- 28. Ground
- 29. Brake Light
- 30. Tail Light

1974 Dniepr MT-10

# Dnepr (Днепр) Early MT-11 and MT-16

with PP-330 Regulator, later replaced with 33.3072 (solid-state)

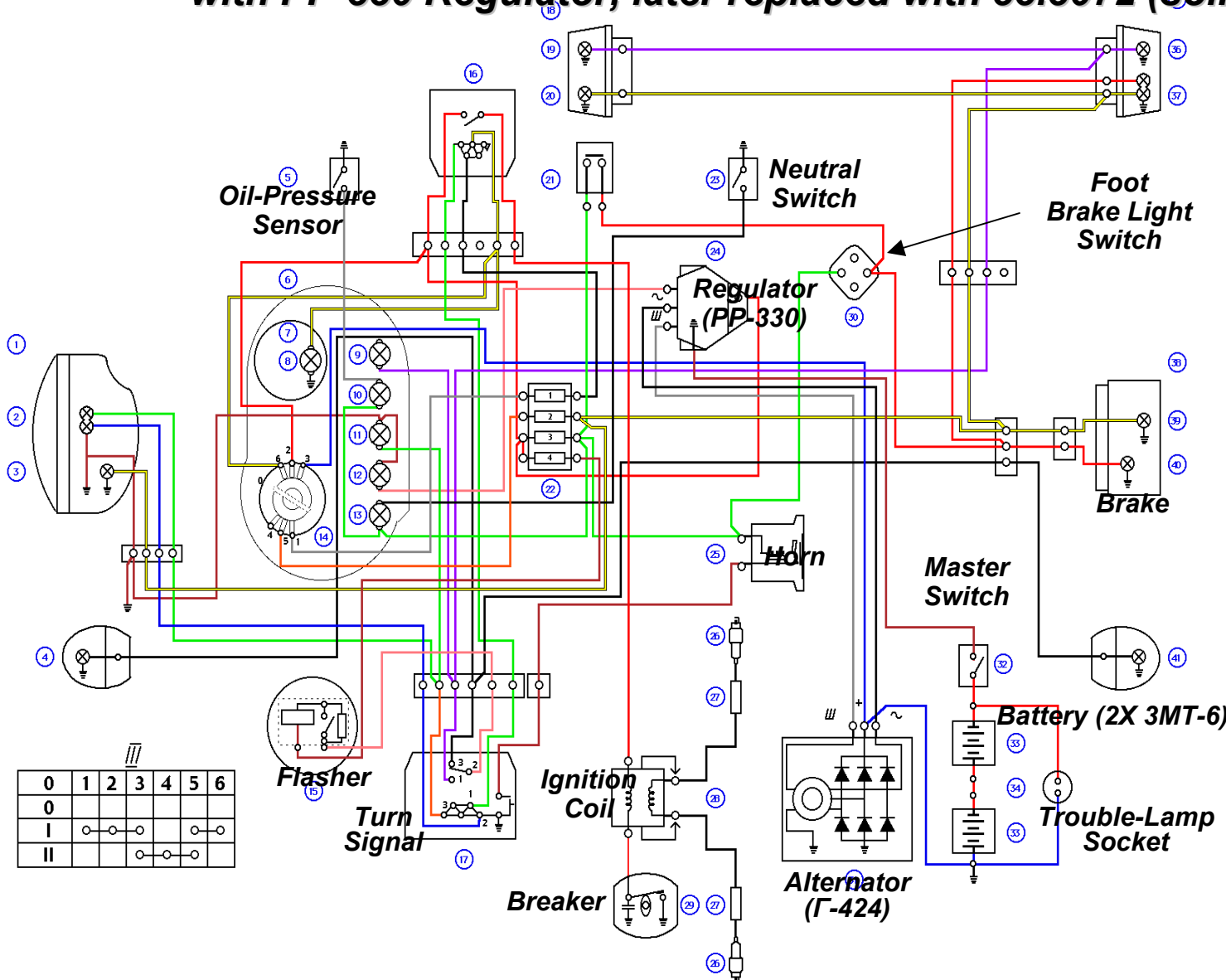

1. Headlamp
2. Hi/Lo beam bulb 45W/40W
3. Parking light
4. Left front turn signal
5. Oil pressure switch
6. Dashboard
7. Speedometer
8. Speedometer light
9. Turn signal indicator
10. Oil pressure indicator
11. High beam indicator
12. Generator indicator
13. Neutral indicator
14. Ignition switch
15. Flasher
16. Right handlebar controls
17. Left handlebar controls
18. Front sidecar lamp
19. Front left turn signal light
20. Front sidecar running light
21. Hand brake stop signal switch
22. Fuse block
23. Neutral switch
24. Voltage regulator PP330
25. Horn
26. Spark plug
27. Noise suppressor
28. Ignition coil
29. Points
30. Rear stop light switch
31. Generator
32. Battery disconnect switch
33. Storage battery
34. Socket 47K
35. Rear sidecar lamp
36. Right rear turn signal bulb
37. Sidecar position and brake light
38. Motorcycle rear lamp
39. License plate light
40. Motorcycle brake light
41. Left rear turn signal

# Migration from the Mechanical (PP-330) to Electronic (33.3702) Regulator

