



***Military Accessories
for
Russian Motorcycles
Part VIII: Driving Lights
and Spot-Lights***

***Ernie Franke
eafranke@tampabay.rr.com
03/2010***

Driving Lights and Spot-Lights

- ***Generator/Alternator Limitations on Lighting***
 - ***Limited Output at Rated RPM***
 - ***Limited Output when Idling***
- ***Spot-Light Mounted in Machine Gun Receiver***
- ***Silver Goose Spot-Lights***
- ***Driving and Fog Lights***
- ***Extra Lighting Needs Relay Control and Wiring***
 - ***Handlebar Switches Aren't Made to Handle Increased Current***
 - ***Wire and Fuses Aren't Meant to Handle Increased Current***
- ***Many Lighting Products Are Not D.O.T. Approved***
 - ***For "off-road or competition"***

Most folks scan their JC Whitney or KC catalog for spot lights, driving lights and fog lights. For good-looking military solutions, it is recommended to check with the Ural people, Silver Goose, Raceway Services, etc.

Generators/Alternators for Ural (Урал) and Dnepr (Днепр)

Generator/ Alternator	Type	Vintage	Nominal Voltage	Current	Nominal Power	Motorcycles	
						Ural(IMZ)	Dnepr (KMZ)
Г-11 (G-11) (P/N: 72181)	DC Generator	1941- 1951	6-Volt (7-Volt)	7-Amp	45-Watts	M-72	Not Used
Г-11А (G-11A) (P/N: 72181-A)	DC Generator	1952- 1957	6-Volt (7-Volt)	7-Amp	45-Watts	M-72, M-72M, M-61	M-72, M-72N, early K-750
Г-414 (G-414) (P/N: 750181)	DC Generator	1957- 1974	6-Volt (7-Volt)	10-Amp	65-Watts	M-62, M-63, M-66	K-650, later K-750, K-750M, MW-750, MW-750M, MT-8, MT-9, MT-12
Г-424 (G-424) (P/N: 3701000)	Alternator (Built-in Rectifier)	1974- 1998	12-Volt (14-Volt)	14-Amp	150-Watts	M-67, M67.36, IMZ 8.103 Series	MW-650, MW-650M, MT-10, MT-10.36, MT-11, MT-16
Hitachi (Limited Appearance)	Alternator/ Starter	1998- 1998.5	12-Volt (14-Volt)	18-Amp	300-Watts	IMZ 8.103 and 8.107 "650" Series	Not Used
14.3771 (RPOC) (P/N: 14.3771-010)	Alternator (Built-in Rectifier & Regulator)	1998.5- 2004	12-Volt (14-Volt)	35-Amp	500-Watts	IMZ 8.103, 8.103X, 8.123, 8.123X "650 & 750" Series	Not Used
Nippon Denso (P/N: IMZ-8.1037-18092)	Alternator (Built-in Rectifier & Regulator)	2004- present	12-Volt (14-Volt)	55-Amp	770-Watts	IMZ 8.103, 8.103X, 8.123, 8.123X "750" Series	Not Used

When considering adding a spotlight or driving lights, one look at the generator/alternator. Not until the short-lived Hitachi or the questionable 14.3771 was there enough extra current for more lighting.

Driving Lights (Silver Goose)



Silver Goose offers a line of driving lights that blend nicely.

Ural/Universal Sidecar Auxiliary Driving Light *(racewayservices.com)*



Another place to mount driving lights!

Driving Light Bars (Raceway Services)



PN 10050

"Dresser" (chrome) style light bar makes you "shine" on the road. Includes two 4" diameter DOT-approved auxiliary driving lights. Pre-wired with 15A toggle switch. Mounts to existing studs under headlight.



PN 10051

Black powder-coated mandrel bent light bar for installing auxiliary driving or fog lamps on your Ural motorcycle. Lights not included. Mounts directly underneath headlight to existing studs and hardware.



PN 10053

Ural/Universal Chrome 7" Diameter Auxiliary Driving Light used with above Light Bar or anywhere else stout enough to keep it from vibrating. "Hoodie" lens ring. Halogen bulb.



PN 10056

Ural/Universal Bullet Style Turn Signal or Running Lights. Classic chrome-plated bullet style turn signal or running lights for your Ural or any other vehicle. Red lens also available.

***You need a bracket to hold those driving lights.
The black bar matches the military décor.***

Silver Goose Spot-Lights

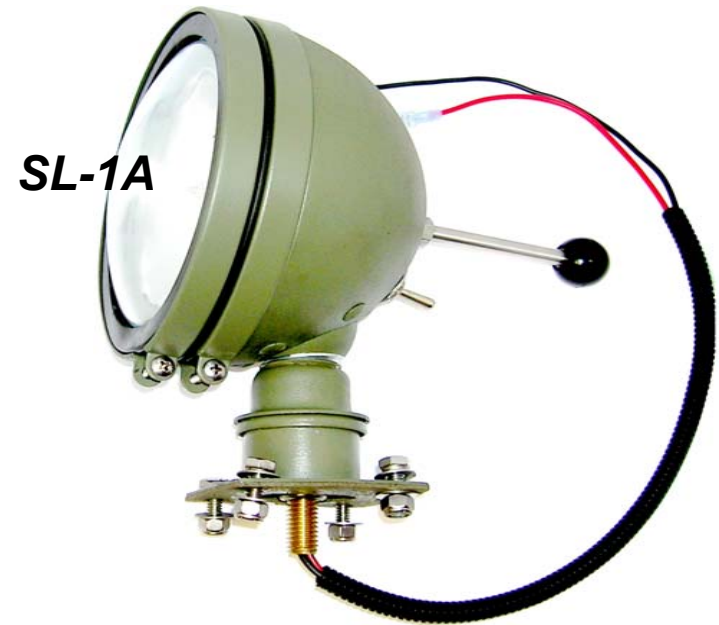

Available with OD Painted, Chrome or Stainless Steel Housing

The spotlight, when properly located, does not interfere with hack windshield when pushed forward. The controls can be reached by either driver or hack passenger, even with the windshield in place.

Driving Light Relay Box (Silver Goose)

***RB-1 Driving Light
Relay Kit***

***RB-2 Battery Wiring
Harness***

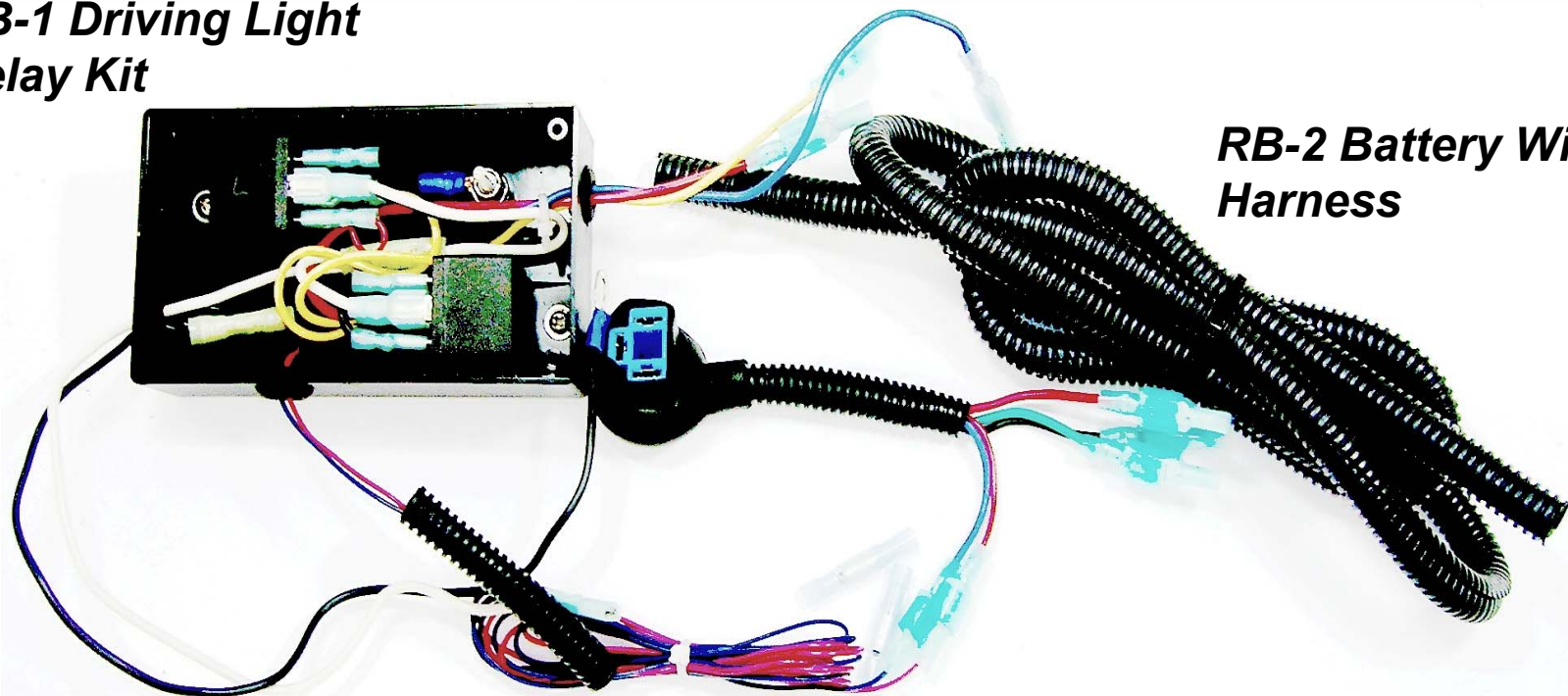

Their heavy-duty light kits are needed to hook extra lights. The two heavy duty relays are actuated by signals from the headlight and power comes from the sidecar fuse box or dedicated line to the battery. You can't just wire it in parallel with the headlight.

Spotlight Installation (silver goose)

- **Mounting the Light**

- **Most Important Part Is Positioning the Light**

- **If Windshield Present or Planned, Place Spotlight Front Enough to Clear it when Windshield Is All the Way Forward**
- **About 2 1/2 inches between Back of Spotlight Base and Apron Loop**

- **After Marking where you want the light**

- **Center-Punch and Cut Center Hole of 5/8" to 1" to Clear the Nut and Allow for Wiring**
- **Recommended Hole-Saw because Large Drills Bits Have Tendency to Grab when Going thru Sheet Metal**

- **When Center hole Is Cut**

- **Position and Square-Up Base**
- **Mark Bolt Holes with Scratch-Awl and Set Spotlight Aside**

- **Center Punch the Markings**

- **Pilot-Drill with a 1/8" Twist-Drill**
- **Drill with 5/16" Twist-Drill**
- **De-bur Inside and Out**

- **Bead of Silicone-Sealant Around Center-Hole Recommended**

- **Thread Wiring Thru and Set Spotlight in position**

- **Bolt Up Base to Hack Tub and Tighten Nuts**

- **Electrical**

- **The Push-In terminal can be connected to a spare on the fuse block in the hack tub. MAKE SURE YOU HAVE A 15 OR 20 AMP FUSE INSTALLED.**

We have broken down the parts into bite-size chunks.

Ural Northwest Spotlight Components

Ural Northwest (uralnw.com)
Sidecar Spotlight Components

Item	Component	IMZ #	Price
2A	Spotlight Assy	8.1031-00019	\$160
2	Spotlight	8.1031P-18061	\$100
5	Spotlight Stand	8.1031P 21094	\$63
7	Wiring Harness	8.1031P-18074	\$28
17	Washer	DIN 9021 M6	\$2
18	Spotlight Flange	8.1031P-21151	\$13
19	Spotlight Spring	62-01419-01	\$5
20	Spotlight Washer	8.1031P-21096	\$15
	Holder	8.1031P-21015	\$32

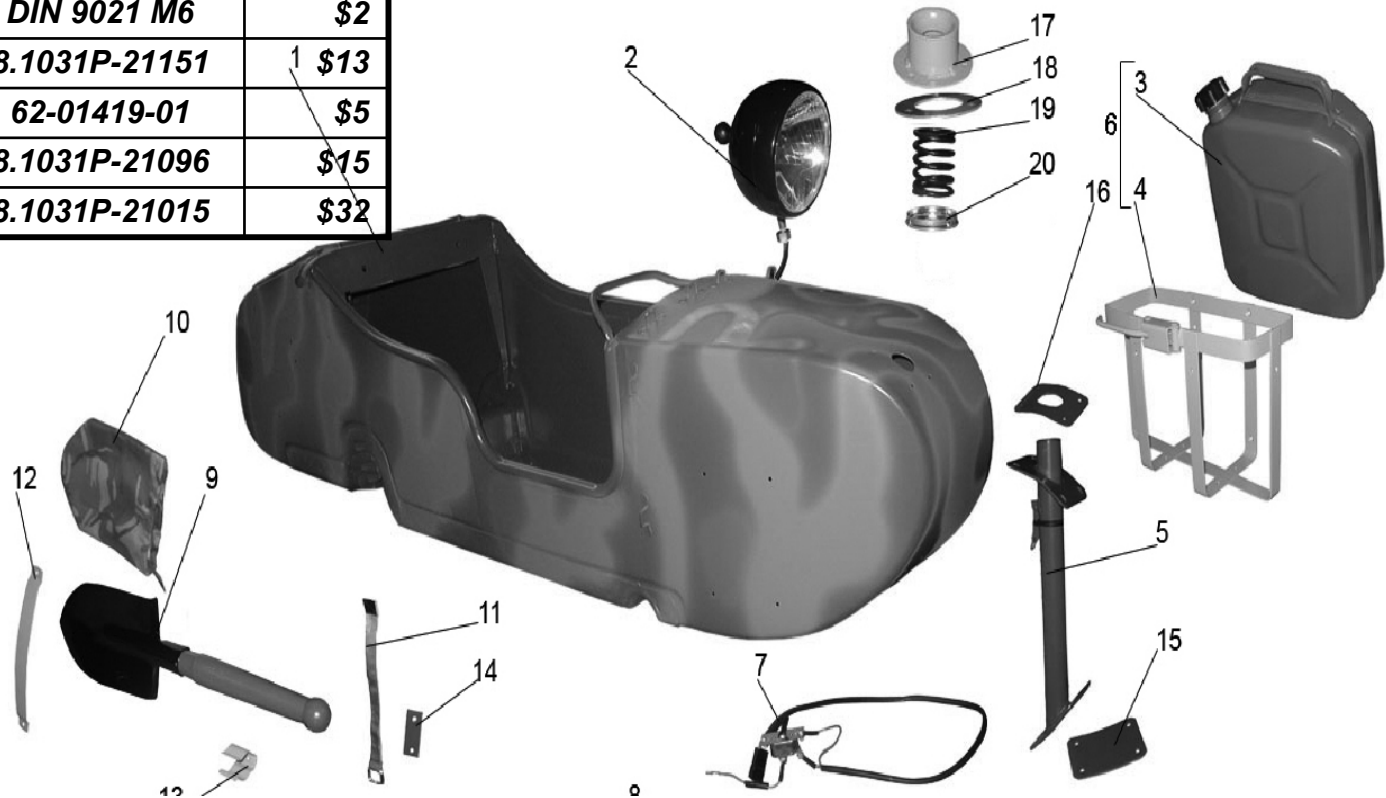

Ural offers the standard spotlight kit.

Hi/Lo Spotlight on Sidecar (f2motorcycles)



F2motorcycles offers an additional light on the nearside front of the sidecar. This is connected to the original Headlight and has both low and high beam and doesn't need to be operated separately using additional switches. Although the sidecar has a small white light on the mudguard, this additional hi/lo light makes it easier for on coming traffic to judge the width of the bike.

Comparative Pricing of Driving Lights

Item	Supplier	Part #	Fits	Approx 2010 Price (USD)
Driving Light, Bumper Mounted w/Olive Drab Steel Housing & Base	Silver Goose	#L-1A	Fits Factory 37mm Bumper	\$71
Driving Light, Bumper Mounted w/Chrome Housing with Aluminum Base	Silver Goose	L-1B	Fits Factory 37mm Bumper	\$69
Driving Light, Deck Mounted w/Olive Drab or Black Steel Housing & Base	Silver Goose	L-2A	Mounts on top or side of car body	\$79
Driving Light, w/Chrome Steel Housing and Polished Aluminum Base	Silver Goose	L-2B	Mounts on top or side of car body	\$74
Driving Light, Nose Mounted w/Olive Drab Steel Housing & Base	Silver Goose	L-3A	Surface Mounts on Hack similar to a MG Mount	\$80
Driving Light, Nose Mounted w/Chrome Housing with Black Painted Base	Silver Goose	L-3B	Surface Mounts on Hack similar to a MG Mount	\$79
Ural/Universal Chrome 7" Diameter Auxiliary Driving Light	racewayservices.com	10053	Looks great on a Wolf or Retro	\$50
Ural/Universal Sidecar Auxiliary Driving Light	racewayservices.com	10054	Mounts on Sidecar Step Bar	\$30
Ural/Universal Bullet Style Turn Signal or Running Lights	racewayservices.com	10056	Classic chrome-plated bullet style	\$30 pair
Spot Light, Military Style Spot Light w/Painted (Olive Drab) Steel Housing & Steel Base	Silver Goose	SL-1A	Specify Color when ordering	\$86
Spot Light for Retro/Tourist/Patrol w/Chrome Steel Housing and Polished Aluminum Base	Silver Goose	SL-1C	for Retro/Tourist/Patrol	\$81
Stainless Steel Spot Light for Retro w/All Stainless-Steel Housing w/Polished Aluminum Base	Silver Goose	SL-1D	Specify Color when ordering	\$100
Spot light with wire harness and mounting gear	ural.ca/pricelista.html	8.103-00019		\$286
Hi/Lo spot light on sidecar	f2motorcycles.ltd.uk		Price includes fitting to a new bike	\$187 (£125)
Driving Light Relay Box	Silver Goose	RB-1		\$43
Battery Wiring Harness	Silver Goose	RB-2	Includes wire and inline fuse for direct wiring to battery	\$16
Spotlight Bar with Spots [Aux Driving Lights]	racewayservices.com	10050	Chrome	\$175
Driving Light Bar	racewayservices.com	10051	Black Powder-Coated	\$80